

Moonwalk Administration Guide



version 12.11

document revision 2

Copyright 2021 Moonwalk Universal Pty Ltd

Contents

1 Overview	1
1.1 Introduction	1
1.2 Conventions used in this Book	1
1.3 System Components	2
1.4 AdminCenter Concepts	3
1.4.1 Servers	3
1.4.2 Sources	4
1.4.3 Destinations	4
1.4.4 Rules	4
1.4.5 Policies	5
1.4.6 Tasks	5
1.4.7 Reports	6
1.4.8 Recovery	6
1.4.9 Settings	6
1.4.10 Help	6
1.5 AdminCenter Dashboard	6
1.5.1 Storage Charts	7
1.5.2 Other Charts	7
1.5.3 Task Control & History	7
2 Deployment	8
2.1 Installing Admin Tools	8
2.1.1 System Requirements	8
2.1.2 Setup	8
2.1.3 Initial Configuration	8
2.2 Installing Agents	9
2.2.1 High-Availability Gateway Configuration	9
2.2.2 Installing Moonwalk Agent for Windows Servers	10
2.2.3 Installing Moonwalk Agent for OES Linux	10
2.3 Installing Moonwalk FPolicy Server for NetApp Filers	11
2.4 Installing Moonwalk LinkConnect Server	11
2.5 LinkConnect Client Deployment	12
2.6 Installing Config Tools	12
3 Usage	13
3.1 DNS Best Practice	13
3.2 Getting Started	13
3.2.1 Analyzing Volumes	13
3.2.2 Migrating Files	14
3.2.3 Next Steps	14
3.3 Configuration Backup	14

CONTENTS

3.3.1	Admin Tools	14
3.3.2	Per-Server Configuration	15
3.4	Storage Backup	16
3.4.1	Backup Planning	16
3.4.2	Backup Process	17
3.4.3	Restore Process	17
3.4.4	Platform-specific Considerations	18
3.5	Production Readiness Checklist	18
3.6	Policy Tuning	19
3.7	System Upgrade	20
3.7.1	Upgrade Procedure	20
3.7.2	Automated Server Upgrade	20
3.7.3	Manual Server Upgrade	20
4	Policy Operation Reference	22
4.1	Gather Statistics Operation	22
4.2	Migrate Operation	22
4.3	Quick-Remigrate Operation	23
4.4	Scrub Destination Operation	23
4.5	Post-Restore Revalidate Operation	24
4.6	Demigrate Operation	24
4.7	Advanced Demigrate Operation	24
4.8	Simple Premigrate Operation	24
4.9	Link-Migrate Operation	25
4.10	Change Destination Tier Operation	25
4.11	Retarget Destination Operation	26
4.12	Ingest Operation	26
4.13	Copy Operation	27
4.14	Move Operation	28
4.15	Additional Copy and Move Options	28
4.16	Create Recovery File From Source Operation	29
4.17	Create Recovery File From Destination Operation	29
4.18	Delete Operation	29
4.19	Erase Cached Data Operation	29
5	Source and Destination Reference	30
5.1	Microsoft Windows	31
5.1.1	Migration Support	31
5.1.2	Planning	31
5.1.3	Setup	31
5.1.4	Usage	31
5.1.5	Interoperability	32
5.1.6	Behavioral Notes	35
5.1.7	Stub Deletion Monitoring	35
5.2	Microsoft Windows via LinkConnect Server	36
5.2.1	Link-Migration Support	36
5.2.2	Planning	36
5.2.3	Setup	38
5.2.4	Usage	40
5.2.5	Known Issues	41
5.3	Micro Focus Open Enterprise Server	42
5.3.1	Migration Support	42
5.3.2	Planning	42
5.3.3	Setup	42

CONTENTS

5.3.4	Usage	42
5.4	NetApp Filer	44
5.4.1	Migration Support	44
5.4.2	Planning	44
5.4.3	Setup	45
5.4.4	Usage	47
5.4.5	Snapshot Restore	48
5.4.6	Interoperability	48
5.4.7	Behavioral Notes	49
5.4.8	Skipping Sparse Files	49
5.4.9	Advanced Configuration	49
5.4.10	Troubleshooting	50
5.5	Dell EMC Isilon NAS	52
5.5.1	Link-Migration Support	52
5.5.2	Planning	52
5.5.3	Setup	54
5.5.4	Usage	56
5.5.5	Known Issues	57
5.6	Caringo Swarm	58
5.6.1	Introduction	58
5.6.2	Planning	58
5.6.3	Setup	59
5.6.4	Plugin Configuration	59
5.6.5	Usage	60
5.6.6	Disaster Recovery Considerations	61
5.6.7	Policy Restrictions	61
5.6.8	Swarm Metadata Headers	61
5.7	Caringo CloudScaler	63
5.7.1	Introduction	63
5.7.2	Planning	63
5.7.3	Setup	64
5.7.4	Plugin Configuration	64
5.7.5	Usage	65
5.7.6	Disaster Recovery Considerations	66
5.7.7	Policy Restrictions	66
5.7.8	Swarm Metadata Headers	66
5.8	Hitachi Content Platform (HCP)	68
5.8.1	Introduction	68
5.8.2	Planning	68
5.8.3	Setup	68
5.8.4	Plugin Configuration	69
5.8.5	Usage	69
5.8.6	Behavioral Notes	70
5.9	Amazon S3	71
5.9.1	Introduction	71
5.9.2	Planning	71
5.9.3	Storage Options	71
5.9.4	Setup	72
5.9.5	Plugin Configuration	72
5.9.6	Usage	73
5.9.7	Ingest Metadata Fields	74
5.9.8	Reduced Redundancy Storage	74
5.10	Aquari Storage	76
5.10.1	Introduction	76

CONTENTS

5.10.2	Planning	76
5.10.3	Setup	76
5.10.4	Plugin Configuration	77
5.10.5	Usage	77
5.10.6	Ingest Metadata Fields	78
5.11	Cloudian HyperStore	79
5.11.1	Introduction	79
5.11.2	Planning	79
5.11.3	Setup	79
5.11.4	Plugin Configuration	80
5.11.5	Compatibility and Limitations	81
5.11.6	Usage	81
5.11.7	Ingest Metadata Fields	81
5.12	Dell EMC Elastic Cloud Storage	82
5.12.1	Introduction	82
5.12.2	Planning	82
5.12.3	Setup	82
5.12.4	Plugin Configuration	83
5.12.5	Usage	84
5.12.6	Ingest Metadata Fields	84
5.13	IBM Cloud Object Storage	85
5.13.1	Introduction	85
5.13.2	Planning	85
5.13.3	Setup	85
5.13.4	Plugin Configuration	86
5.13.5	Usage	87
5.13.6	Ingest Metadata Fields	87
5.14	IBM Spectrum Scale	88
5.14.1	Introduction	88
5.14.2	Planning	88
5.14.3	Setup	88
5.14.4	Plugin Configuration	89
5.14.5	Usage	90
5.14.6	Ingest Metadata Fields	90
5.15	NetApp StorageGRID	91
5.15.1	Introduction	91
5.15.2	Planning	91
5.15.3	Setup	91
5.15.4	Plugin Configuration	92
5.15.5	Usage	93
5.15.6	Ingest Metadata Fields	93
5.16	Scality RING	94
5.16.1	Introduction	94
5.16.2	Planning	94
5.16.3	Setup	94
5.16.4	Plugin Configuration	95
5.16.5	Usage	96
5.16.6	Ingest Metadata Fields	96
5.17	Generic S3 Endpoint	97
5.17.1	Introduction	97
5.17.2	Planning	97
5.17.3	Setup	98
5.17.4	Plugin Configuration	98
5.17.5	Usage	99

CONTENTS

5.17.6	Ingest Metadata Fields	100
5.18	Microsoft Azure Storage	101
5.18.1	Introduction	101
5.18.2	Planning	101
5.18.3	Setup	101
5.18.4	Plugin Configuration	102
5.18.5	Usage	103
5.19	Google Cloud Storage	104
5.19.1	Introduction	104
5.19.2	Planning	104
5.19.3	Setup	104
5.19.4	Storage Bucket Preparation	104
5.19.5	Plugin Configuration	105
5.19.6	Usage	106
5.20	Alibaba Cloud Object Storage Service (OSS)	107
5.20.1	Introduction	107
5.20.2	Planning	107
5.20.3	Setup	107
5.20.4	Plugin Configuration	108
5.20.5	Usage	108
5.21	Built-in NFS Client	110
5.21.1	Introduction	110
5.21.2	Planning	110
5.21.3	Setup	110
5.21.4	Usage	111
5.21.5	Behavioral Notes	111
5.22	SMB Protocol Gateway	112
5.22.1	Introduction	112
5.22.2	Planning	112
5.22.3	Setup	112
5.22.4	Usage	112
5.22.5	Behavioral Notes	113
6	Disaster Recovery	114
6.1	Introduction	114
6.2	Recovery Files	114
6.3	Filtering Results	114
6.4	Recovering Files	115
6.5	Recovering Files to a New Location	116
6.6	Updating Sources to Reflect Destination URI Change	116
6.7	Using DrTool from the Command Line	116
6.8	Querying a Destination	118
A	Pattern Matching Reference	119
A.1	Wildcard Patterns	119
A.1.1	Directory Exclusion Patterns	120
A.2	Regular Expressions	120
B	Network Ports	121
B.1	Admin Tools	121
B.2	Agent / FPolicy Server / LinkConnect Server	121
C	AdminCenter Security Configuration	123
C.1	Updating the AdminCenter TLS Certificate	123
C.2	Password Reset	123

CONTENTS

C.3 Authentication with Active Directory	123
C.4 Authentication with eDirectory	124
D API Access	125
D.1 Management API	125
D.2 Service Probe	125
E Advanced Agent Configuration	126
E.1 Syslog Configuration	126
E.2 Stub Deletion Monitoring	126
E.3 Logging and Debug Options	127
E.4 Parallelization Tuning Parameters	127
E.5 Advanced NFS Settings	127
E.6 Demigration Blocking	128
F Troubleshooting	129
F.1 Log Files	129
F.2 Interpreting Errors	130
F.3 Getting Help	132
F.4 Contacting Support	132
G Glossary	133

Chapter 1

Overview

1.1 Introduction

Moonwalk is a heterogeneous Data Management System. It automates and manages the movement of data from primary storage locations to lower cost file systems, object stores, tape or cloud storage services.

Files are *migrated* from primary storage locations to secondary storage locations. Files are *demigrated* transparently when accessed by a user or application. Moonwalk also provides functionality to copy and move files, as well as a range of Disaster Recovery options.

What is Migration?

From a technical perspective, file migration can be summarized as follows: first, the file content and corresponding metadata are copied to secondary storage as an MWI file/object. Next, the original file is marked as a 'stub' and truncated to zero *physical* size (while retaining the original *logical* size for the benefit of users and the correct operation of applications). The resulting stub file will remain on primary storage in this state until such time as a user or application requests access to the file content, at which point the data will be automatically returned to primary storage.

Each stub encapsulates the location of the corresponding MWI data on secondary storage, without the need for a database or other centralized component.

1.2 Conventions used in this Book

References to **labels, values and literals** in the software are in *'quoted italics'*.

References to **actions**, such as clicking buttons, are in **bold**.

References to **commands and text typed in** are in `fixed font`.

Notes are denoted: **Note:** This is a note.

Important notes are denoted: **Important: Important point here.**

1.3. SYSTEM COMPONENTS

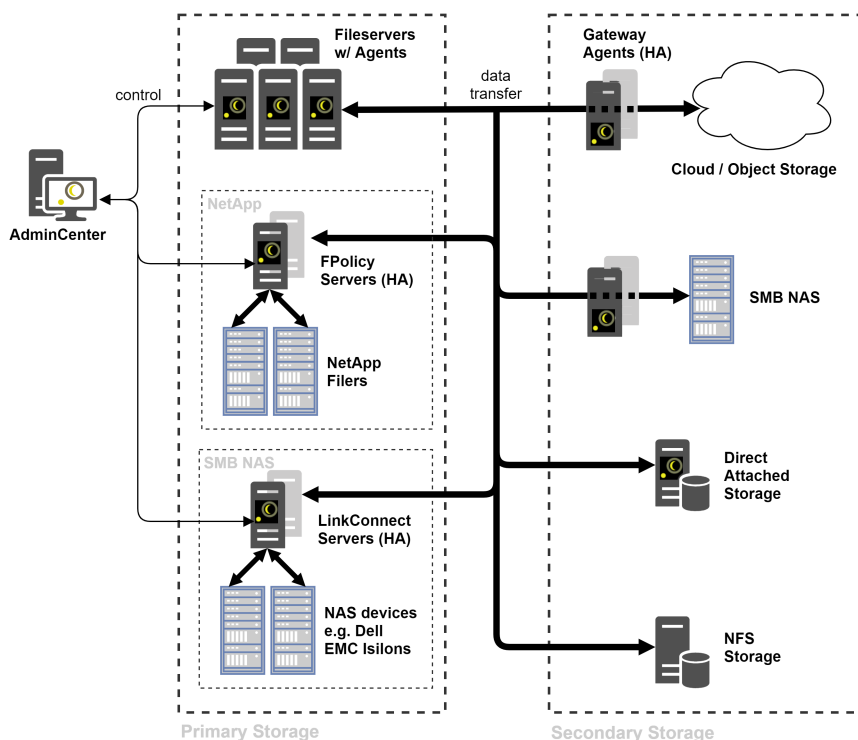

Figure 1.1: Moonwalk System Overview

1.3 System Components

Figure 1.1 provides an overview of a Moonwalk system. All communication between Moonwalk components is secured with Transport Layer Security (TLS). The individual components are described below.

Moonwalk AdminCenter

AdminCenter is the system's policy manager. It provides a centralized web-based configuration interface, and is responsible for task scheduling, server monitoring and file reporting. It lies outside the data path for file transfers.

Moonwalk Agent

Moonwalk Agent performs file operations as directed by AdminCenter Policies. The Agent is also responsible for retrieving file data from secondary storage upon user / application access.

File operations include migration, move, copy and demigration, as well as a range of operations to assist disaster recovery. Data is streamed directly between agents and storage without any intermediary staging on disk.

1.4. ADMINCENTER CONCEPTS

When installed in a Gateway configuration, Agent may function as a plugin container which allows Moonwalk to be extended to enable access to third-party protocols and special devices. Device specific configuration details (such as sensitive encryption keys and authentication details) are contained and isolated from the file servers.

Optionally, Gateways can be configured for High-Availability (HA).

Moonwalk FPolicy Server

FPolicy Server provides migration support for NetApp filers via the NetApp FPolicy protocol. This component is the equivalent of Moonwalk Agent for NetApp filers.

FPolicy Server may also be configured for High-Availability (HA).

Moonwalk LinkConnect Server

LinkConnect Server provides link-based migration support for either Dell EMC Isilon NAS or as an alternative method for migrating files from Windows Server volumes in the case where an agent may not be installed directly on the file server. This component performs a similar role to Moonwalk Agent for SMB shares.

LinkConnect Server may also be configured for High-Availability (HA).

Moonwalk DrTool

Moonwalk DrTool is an additional application that assists in Disaster Recovery scenarios.

Note: This functionality is not included with *Starter Edition* licenses.

1.4 AdminCenter Concepts

Moonwalk AdminCenter is the web-based interface that provides central management of a Moonwalk deployment. It is installed as part of the Admin Tools package.

When entering the AdminCenter, the *'Dashboard'* will be displayed – we will come back to the dashboard in §1.5. For now, the remainder of this section will follow the AdminCenter's navigation menu.

1.4.1 Servers

The *'Servers'* page displays the installed and activated agents across the deployment of Moonwalk. Health information and statistics are provided for each server or cluster node. You will use this page when activating the other components in your system.

Click a Server's ellipsis control to:

- view additional server information such as installed plugins
- edit server-specific configuration details (see Appendix E)

1.4. ADMINCENTER CONCEPTS

- add / retire / restart nodes
- upgrade a standalone server to high-availability
- view detailed charts of recent file operations

Note: where an operation is performed across multiple servers, the operation is reflected in the source server's charts only.

1.4.2 Sources

Sources describe volumes or folders to which Policies may be applied (e.g., locations on the network from which files may be Copied, Moved or Migrated).

A Source location is specified by a URI. Platform-specific information for all supported sources – including their URI schemes – is detailed in Chapter 5. A filesystem browser is provided to assist in setting the URI location interactively.

Subdirectory Filtering

Within a given Source, individual directory subtrees may be included or excluded to provide greater control over which files are eligible for policy operations. Excluded directories will not be traversed.

In the Source editor, the directory tree may be expanded and explored in the '*Subdirectory Filtering*' section. By default, the entire source will be included.

1.4.3 Destinations

Destinations are storage locations that Policies may write files to (e.g., locations on the network to which files are Copied, Moved or Migrated).

Destinations are specified by entering a URI using the browser panel – if the specified folder does not exist, it will be created at Task execution time.

Optionally, a Destination may be configured to use Write Once Read Many (WORM) semantics for migration operations. No attempt will be made thereafter to update the resultant secondary storage objects. This option is useful when the underlying storage device has WORM-like behavior, but is exposed using a generic protocol.

1.4.4 Rules

Rules allow a specific subset of files within a Source or Sources to be selected for processing.

Rules can match a variety of metadata: filename / pathname, size, timestamps / age, file owner, and attribute flags. A rule matches if **all** of its specified criteria match the file's metadata. However, rules can be negated or compounded as necessary to perform more complex matches.

You will be able to simulate your Rules against your Sources during Policy creation.

Some criteria are specified as comma-separated lists of patterns:

1.4. ADMINCENTER CONCEPTS

- wildcard patterns, e.g. *.doc (see §A.1 (p.119))
- regular expressions, e.g. /2004-06-[0-9][0-9]\.log/ (see §A.2 (p.120))

Note that:

- files match if any one of the patterns in the list match
- whitespace before and after each pattern is ignored
- patterns are case-insensitive
- filename patterns starting with '/' match the path from the point specified by the Source URI
- filename patterns NOT starting with '/' match files in any subtree
- literal commas within a pattern must be escaped with a backslash

1.4.5 Policies

A Policy specifies an *operation* to perform on a set of files. Depending on the type of operation, a Policy will specify Source(s) and/or Destination(s), and possibly Rules to limit the Policy to a subset of files.

Each operation has different parameters, refer to Chapter 4 for a full reference.

1.4.6 Tasks

A Task schedules one or more Policies for execution. Tasks can be scheduled to run at specific times, or can be run on-demand via the **Quick Run** control on the *'Dashboard'*.

While a Task is running, its status is displayed in the *'Running Tasks'* panel of the *'Dashboard'*. When Tasks finish they are moved to the *'Recent Tasks'* panel.

Operation statistics are updated in real time as the task runs. Operations will automatically be executed in parallel, see §E.4 (p.127) for more details.

If multiple Tasks are scheduled to start simultaneously, Policies on each Source are grouped such that only a single traversal of each file system is required.

Completion Notification

When a Task finishes running, regardless of whether it succeeds or fails, a completion notification email may be sent as a convenience to the administrator. This notification email contains summary information similar to that available in the *'Recent Tasks'* panel on the *'Dashboard'*.

To use this feature, either:

- check the *'Notify completion'* option when configuring the Task, or
- click the notify icon on a running task on the *'Dashboard'*

1.4.7 Reports

Reports – generated by Gather Statistics Policies – contain charts detailing:

- a 30-day review of access and change activity
- a long-term trend chart to assist with planning migration strategy
- a breakdown of the most common file types
- optionally, a breakdown of file ownership

1.4.8 Recovery

The *'Recovery'* page provides access to multiple versions of the recovery files produced by each *Create Recovery File From Source/Destination* Policy. Retention options may be adjusted in *'Settings'*.

Refer to Chapter 6 for more information on performing recovery operations.

1.4.9 Settings

The AdminCenter *'Settings'* page allows configuration of a wide range of features including:

- email notification
- configuration backup (see §3.3 (p.14))
- work hours
- logging
- user interface language selection

It is also possible to suspend the scheduler, to prevent scheduled Tasks starting while maintenance procedures are being performed.

1.4.10 Help

The Help page provides version information, as well as links to documentation and support resources. You may also view the global log, or generate a system diagnostic file (*support.zip*) for use when contacting Moonwalk Support.

1.5 AdminCenter Dashboard

The *'Dashboard'* provides a concise view of the Moonwalk system status, current activity and recent task history. It may also be used to run Tasks on-demand via the Quick Run control.

The *'Notices'* panel, displayed on the expandable graph bar, summarizes system issues that need to be addressed by the administrator. For instance, this panel will guide you through initial setup tasks such as license installation.

The circular *'Servers'* display shows high-level health information for the servers / clusters in the Moonwalk deployment.

1.5. ADMINCENTER DASHBOARD

For capacity-based licenses, license capacity consumption is shown on the *'Usage'* panel.

1.5.1 Storage Charts

'Primary' and *'Secondary'* storage charts may be read together to gain insight into the impact of currently configured migration policies on primary and secondary storage consumption over time. Each bar indicates an amount of storage space consumed or released. Consumed storage is indicated by a positive bar, while released storage is shown in the negative. Stacked bars indicate the contributions of the different operations by color.

For instance, a Migration Policy consumes secondary storage in order to release primary storage.

By contrast, demigration consumes primary storage immediately, but defers release until later. Specifically, either the primary storage is released by a Quick-Remigrate, or the associated secondary storage is released by a Scrub.

In a complex environment, these charts provide insight into patterns of user-behavior and policy activity.

Click on a bar to zoom in to an hourly breakdown for the chosen day.

1.5.2 Other Charts

The *'Processed'* line chart graphs both the rate of operations successfully performed and data processed over time. Data transfer and bytes Quick-Remigrated (i.e. without any transfer required) are shown separately.

The *'Operations'* breakdown chart shows successful activity by operation type across the whole system over time. Additionally, per-server operations charts are available via the *'Servers'* page – see §1.4.1.

The *'Operations'* radar chart shows a visual representation of the relative operation profile across your deployment. Two figures are drawn, one for each of the two preceding 7-day periods. This allows behavioral change from week to week to be seen at a glance.

1.5.3 Task Control & History

Per-file operation details (including any error messages) may be viewed by clicking a Task's log icon. It is also possible to start and stop Tasks, update task configuration, or request a completion notification for a task that is already in progress.

Chapter 2

Deployment

Refer to these instructions during initial deployment and when adding new components. For upgrade instructions, please refer to §3.7 (p.20) instead.

For further information about each supported storage platform, refer to Chapter 5.

2.1 Installing Admin Tools

The Moonwalk Admin Tools package consists of the AdminCenter and the DrTool application (not licensed for *Starter Edition* users). Admin Tools must be installed before any other components.

2.1.1 System Requirements

- A **dedicated** server with a supported operating system:
 - Windows Server 2019
 - Windows Server 2016
 - Windows Server 2012 R2
 - Windows Server 2012
- Minimum 4GB RAM
- Minimum 2GB disk space for log files
- Active clock synchronization (e.g. via NTP)

2.1.2 Setup

1. Run `Moonwalk Admin Tools.exe`
2. Follow the instructions on screen

2.1.3 Initial Configuration

After completing the installation process, Admin Tools must be configured via the AdminCenter web interface. The AdminCenter will be opened automatically and can be

2.2. INSTALLING AGENTS

found later via the Start Menu.

The web interface will lead you through the process of initial configuration: refer to the 'Notices' panel on the 'Dashboard' to ensure that all steps are completed.

NFS Browser Agent

If you are planning to use NFS storage, Moonwalk Gateway Agent should also be installed on the same server as Admin Tools. Remember to install this when installing other Agents.

2.2 Installing Agents

Each Agent server may fulfill one of two roles, selected at installation time.

In the '*Fileserver Agent for migration*' role, an agent assists the operating system to migrate and demigrate files. It is **essential** for the agent to be installed on all machines from which files will be migrated.

By contrast, in the '*Gateway Agent*' role, an agent provides access to external devices and storage services. While it does allow access to local disk and mounted SAN volumes, it does not provide local migration source support.

2.2.1 High-Availability Gateway Configuration

When using Gateway Agents to access third-party devices using Moonwalk plugins or the `smb` scheme, a high-availability gateway configuration is recommended. Such Gateway Agents must be activated as 'High-Availability Gateway Agents'.

When using Gateway Agents in a failover cluster to access a mounted SAN volume, each node must be activated as a 'Windows Failover Cluster' node or 'OES Linux Cluster' node as appropriate. Please refer to the installation section for the specific operating system.

High-Availability Gateway DNS Setup

At least two Gateway Agents are required for High-Availability.

1. Add each Gateway Agent server to DNS
2. Create an FQDN that resolves to all of the IP addresses
3. Use this FQDN when activating the HA Servers
4. Use this FQDN (or a CNAME alias to it) in Moonwalk Destination URIs

Example:

- `gw-1.example.com` → `192.168.0.1`
- `gw-2.example.com` → `192.168.0.2`
- `gw.example.com` → `192.168.0.1, 192.168.0.2`

Note: The servers that form the High-Availability Gateway cluster must NOT be members of a Windows failover cluster.

2.2.2 Installing Moonwalk Agent for Windows Servers

System Requirements

- Supported Windows Server operating system:
 - Windows Server 2019
 - Windows Server 2016
 - Windows Server 2012 R2
 - Windows Server 2012
- Minimum 4GB RAM
- Minimum 2GB disk space for log files
- Active clock synchronization (e.g. via NTP)

Note: When installed in the Gateway role, a **dedicated** server is required, unless it is to be co-located on the Admin Tools server. When co-locating, create separate DNS aliases to refer to the Gateway and the AdminCenter web interface.

Setup

1. Run the `Moonwalk Agent.exe`
2. Follow the instructions to activate the agent via AdminCenter

2.2.3 Installing Moonwalk Agent for OES Linux

System Requirements

- Supported Micro Focus Open Enterprise Server 2015 SP1 (eDirectory environments only)
- Minimum 1GB RAM
- Minimum 2GB disk space for log files
- Active clock synchronization (e.g. via NTP)

Setup

1. Run `nssmu` and enable the Migration flag for each of the volumes that will have stub files. Any volumes added after install time will also need this flag set. Failing to change this setting will affect backup and restore of stubs.
 - `nssmu → volumes → properties → set 'Migration' to 'YES'`
2. Install the appropriate rpm using:
 - `rpm -U moonwalk_agent_oes2015...x86_64.rpm`
3. Begin the activation process by running
 - `/var/lib/moonwalk/activateServer`
4. Follow the instructions to activate the agent via AdminCenter

2.3 Installing Moonwalk FPolicy Server for NetApp Filers

A Moonwalk FPolicy Server provides migration support for one or more NetApp Filers through the FPolicy protocol. This component is the equivalent of Moonwalk Agent for NetApp Filers. Typically FPolicy Servers are installed in a high-availability configuration.

System Requirements

- A **dedicated** server with a supported operating system:
 - Windows Server 2019
 - Windows Server 2016
 - Windows Server 2012 R2
 - Windows Server 2012
- Minimum 4GB RAM
- Minimum 2GB disk space for log files
- Active clock synchronization (e.g. via NTP)

Setup

Installation of the FPolicy Server software requires careful preparation of the NetApp Filer and the FPolicy Server machines. Instructions are provided in §5.4 (p.44).

2.4 Installing Moonwalk LinkConnect Server

A Moonwalk LinkConnect Server provides link-based migration support for one or more Isilon or Windows SMB shares. This component performs a similar role to Moonwalk Agent without the need for software to be installed directly on the NAS or file server.

System Requirements

- A **dedicated** server with a supported operating system:
 - Windows Server 2019
 - Windows Server 2016
- Minimum 2GB disk space for log files (on the system volume)
- Minimum 1TB disk space for LinkConnect Cache (as a single NTFS volume)
- RAM: 8GB base, **plus**:
 - 4GB per TB of LinkConnect Cache
 - 0.5GB per billion link-migrated files
- Active clock synchronization (e.g. via NTP)

Setup

Installation of the LinkConnect Server software requires careful configuration of both the NAS / file server and the LinkConnect Server machines. Instructions are provided

2.5. LINKCONNECT CLIENT DEPLOYMENT

in §5.5 (p.52) for Dell EMC Isilon and §5.2 (p.36) for Windows file servers. Other devices are not supported.

2.5 LinkConnect Client Deployment

Installation

Having deployed one or more LinkConnect Servers, all Windows clients that will need to access link-migrated files will require the LinkConnect Client Driver to be installed as follows:

1. Ensure the client machine is joined to the Active Directory domain
2. Run `Moonwalk LinkConnect Client Driver.exe`
3. Follow the prompts

Alternatively to ease deployment, the installer may be run in silent mode by specifying `/S` on the command line. Note that when upgrading the driver silently, the updated driver will not be loaded until the next reboot.

Important: Client Driver versions newer than the installed LinkConnect Server version should not be deployed.

Deployment Considerations

Access to NAS / file server shares containing files that have been link-migrated must use the domain credentials of the logged-in Windows desktop session. When a user accesses a link-migrated file, the client driver will transparently redirect the access to the LinkConnect Server if required. This redirected access will use the same logged-in Windows desktop session credentials.

Installation of the client driver will enable remote symlink evaluation in Windows. If remote symlink evaluation was disabled prior to client driver installation (this is the default behavior in Windows 10), the driver will continue to prevent remote symlink access for other symlinks. Do not disable remote symlink evaluation (e.g. by group policy) after installation since doing so will cause the client driver to stop functioning.

2.6 Installing Config Tools

In addition to the components described above, it may also be necessary to install one or more Config Tools. Full details are provided where required for each storage platform in Chapter 5.

Chapter 3

Usage

3.1 DNS Best Practice

Storage locations in Moonwalk are referred to by URI. Relationships between files must be maintained over a long period of time. It is therefore advisable to take steps to ensure that the FQDNs used in these URIs are valid long-term, even as individual server roles are changed or consolidated.

In a production deployment, always use Fully Qualified Domain Names (FQDNs) in preference to bare IP addresses.

It is recommended to create DNS aliases for each logical storage role for each server. For example, use different DNS aliases when storing your finance department's data as opposed to your engineering department's data – even if they initially reside on the same server.

3.2 Getting Started

3.2.1 Analyzing Volumes

Once the software has been installed, the first step in any new Moonwalk deployment is to analyze the characteristics of the primary storage volumes. The following steps describe how to generate file statistics reports for each volume.

In the AdminCenter web interface:

1. Create Sources for each volume to analyze
2. Create a 'Gather Statistics' Policy and select all defined Sources
3. Create a Task for the 'Gather Statistics' Policy
 - For now, disable the schedule
4. On the '*Dashboard*', click the Quick Run icon
5. Run the Task
6. When the Task has finished, view the report(s) on the '*Reports*' page

3.2.2 Migrating Files

Using the information from the reports, create a rule to select files for migration. A typical rule might limit migrations to files modified more than six months ago. The reports' long-term trend charts will indicate the amount of data that will be migrated by a 'modified more than n months ago' rule – adjust the age cutoff as necessary to suit your filesystems.

To avoid unnecessary migration of active files, be conservative with your first Migration Rule – it can be updated to migrate more recently modified files on subsequent runs.

Once the Rule has been created:

1. Create a Destination to store your migrated data
 - see Chapter 5 for platform-specific instructions
2. Create a Migration Policy and add the Source(s), Rule and Destination
3. Use the 'Simulate rule matching...' button to explore the effect of your rule
4. Create a Task for the new Policy
5. Run the task

When the task has completed, check the corresponding 'Recent Tasks' entries on the 'Dashboard'. Click on the log icon to review any errors in detail.

Migration is typically performed periodically: configure a schedule on the Migration Task.

3.2.3 Next Steps

Chapter 4 describes all Moonwalk Policy Operations in detail and will help you to get the most out of Moonwalk.

The remainder of this chapter gives guidance on using Moonwalk in a production environment.

3.3 Configuration Backup

This section describes how to backup Moonwalk configuration (for primary and secondary storage backup considerations, see §3.4).

3.3.1 Admin Tools

Backing up the Moonwalk Admin Tools configuration will preserve policy configuration and server registrations as configured in the AdminCenter.

Backup Process

Configuration backup can be scheduled on the AdminCenter's 'Settings' page. A default schedule is created at installation time to backup configuration once a week.

Configuration backup files include:

3.3. CONFIGURATION BACKUP

- Policy configuration
- Server registrations
- Recovery files
- Settings from the AdminCenter *'Settings'* page
- Settings specified when Admin Tools was installed

It is recommended that these backup files are retrieved and stored **securely** as part of your overall backup plan. These backup files can be found at:

C:\Program Files\Moonwalk\data\AdminCenter\configBackups

Additionally, log files may be backed up from:

- C:\Program Files\Moonwalk\logs\AdminCenter\
- C:\Program Files\Moonwalk\logs\drtool\

Restore Process

1. Ensure that the server to be restored to has the same FQDN and IP address as the original server
2. If present, uninstall Moonwalk Admin Tools
3. Run the installer: Moonwalk Admin Tools.exe
 - use the same version that was used to generate the backup file
4. On the *'Installation Type'* page, select *'Restore from Backup'*
5. Choose the backup zip file and follow the instructions
6. Optionally, log files may be restored from server backups to:
 - C:\Program Files\Moonwalk\logs\AdminCenter\
 - C:\Program Files\Moonwalk\logs\drtool\

3.3.2 Per-Server Configuration

Backing up the configuration on each server will allow for easier redeployment of agents in the event of disaster.

Windows Backup Process

On each Windows Server backup the entire installation directory.

e.g. C:\Program Files\Moonwalk\

Windows Restore Process

On each replacement server:

1. Reinstall with the same version of the installer
2. Stop the *'Moonwalk Agent'* service
3. Restore the contents of the following directories from backup:
 - C:\Program Files\Moonwalk\data\Agent\
 - C:\Program Files\Moonwalk\logs\Agent\
4. Restart the *'Moonwalk Agent'* service

3.4. STORAGE BACKUP

OES Linux Backup Process

On each Moonwalk Agent machine backup the following files and directories:

- /etc/moonwalk/
- /var/log/moonwalk/
- /etc/sysconfig/mw-agent

OES Linux Restore Process

On each replacement server:

1. Reinstall with the same version of the rpm
 - Do NOT activate the server
2. Restore the following files and directories from backup:
 - /etc/moonwalk/
 - /var/log/moonwalk/
 - /etc/sysconfig/mw-agent
3. Run `service mw-agent start`

3.4 Storage Backup

Each stub on primary storage is linked to a corresponding MWI file on secondary storage. During the normal process of migration and demigration the relationship between stub and MWI file is maintained.

The recommendations below ensure that the consistency of this relationship is maintained even after files are restored from backup.

3.4.1 Backup Planning

Ensure that the restoration of stubs is included as part of your backup & restore test regimen.

When using Scrub policies, ensure the Scrub grace period is sufficient to cover the time from when a backup is taken to when the restore *and* Post-Restore Revalidate steps are completed (see below).

It is **strongly** recommended to set the global *minimum* grace period accordingly to guard against the accidental creation of scrub policies with insufficient grace. This setting may be configured on that AdminCenter *'Settings'* page.

Important: It will NOT be possible to safely restore stubs or MigLinks from a backup set taken more than one grace period ago.

Additional Planning

To complement standard backup and recovery solutions, and to allow the widest range of recovery options, it is recommended to schedule a *'Create Recovery File From Source'* Policy to run after each migration.

3.4.2 Backup Process

Perform these backup steps in the following order:

1. Backup primary storage volumes
2. Backup secondary volumes/devices (if necessary)
 - Allow primary backup to **complete** first
 - Secondary may be backed up less frequently than primary

Usually, backup will be scheduled to run a little while after migration policies have completed.

Note: When adding backup jobs, always recheck the minimum grace period setting for scrub (see above).

3.4.3 Restore Process

If primary *and* secondary volumes are to be restored:

1. Suspend the scheduler in AdminCenter
2. Restore the primary volume
3. Restore the corresponding secondary volume from a **newer** backup set than the primary
4. Run a '*Post-Restore Revalidate*' policy against the primary volume
 - To ensure all stubs are revalidated, run this policy against the **entire** primary volume, NOT simply against the migration source
 - This policy is not required when *only* WORM destinations are in use
5. Restart the scheduler in AdminCenter

If *only* primary is to be restored (including where secondary is cloud storage):

1. Suspend the scheduler in AdminCenter
2. Restore the primary volume
3. Run a '*Post-Restore Revalidate*' policy against the primary volume
 - To ensure all stubs are revalidated, run this policy against the **entire** primary volume, NOT simply against the migration source
 - This policy is not required when *only* WORM destinations are in use
4. Restart the scheduler in AdminCenter

If restoring the primary volume to a different server (a server with a different FQDN), the following preparatory steps will also be required:

1. On the '*Servers*' page, retire the old server (unless still in use for other volumes)
2. Install Agent on the new server
3. Update Sources as required to refer to the FQDN of the new server
4. Perform the restore process as above

3.4.4 Platform-specific Considerations

Windows

Most enterprise Windows backup software will respect the Offline flag. Refer to the backup software user guide for options regarding Offline files.

When testing backup software configuration, test that backup of stubs does not cause unwanted demigration.

Additional backup testing may be required if Stub Deletion Monitoring is required. Please refer to §E.2 (p.126) for more details.

NetApp Filers

Please consult §5.4.5 (p.48) for information regarding snapshot restore on NetApp Filers.

OES Linux

Configure backup software to NOT demigrate stubs (the options in the software may refer to Migrated files, Archived files, Offline files or HSM files).

Where the backup software does not provide an option to backup stubs only, TSAFS can be configured to block demigrations during backup:

1. Open `/etc/opt/novell/sms/tsafs.conf` in a text editor
2. Add a single line:
 - `doNotDemigrate`
3. Save the file
4. The configuration change will take effect when the server is restarted, or when TSAFS is restarted
5. Restart TSAFS:
 - (a) `/opt/novell/sms/bin/smsconfig -u tsafs`
 - (b) `/opt/novell/sms/bin/smsconfig -l tsafs`

To ensure restore jobs function correctly, NSS volumes should have the Migration flag set to YES for each volume:

- `nssmu → volumes → properties → set 'Migration' to 'YES'`

3.5 Production Readiness Checklist

Backup

1. Check your Moonwalk configuration is adequately backed up – see §3.3
2. Review the *storage* backup and restore procedures described in §3.4
3. Check backup software can backup stubs without triggering demigration
4. Check backup software restores stubs and that they can be demigrated
5. Schedule regular *'Create Recovery File From Source'* Policies on your migration sources

Antivirus

Generally, antivirus software will not cause demigrations during normal file access. However, some antivirus software will demigrate files when performing scheduled file system scans.

Prior to production deployment, always check that installed antivirus software does not cause unwanted demigrations. Some software must be configured to skip offline files in order to avoid these inappropriate demigrations. Consult the antivirus software documentation for further details.

If the antivirus software does *not* provide an option to skip offline files during a scan, Moonwalk Agent may be configured to deny demigration rights to the antivirus software. Refer to §E.6 (p.128) for more information.

It may be necessary for some antivirus products to exempt the Moonwalk Agent process from real-time protection (scan-on-access). If the exclusion configuration requires the path of the executable to be specified, be sure to update the exclusion whenever Moonwalk is upgraded (since the path will change on upgrade).

Other System-wide Applications

Check for other applications that open all the files on the whole volume. Audit scheduled processes on file servers – if such processes cause unwanted demigration, it may be possible to block them (see §E.6 (p.128)).

Monitoring and Notification

To facilitate proactive monitoring, it is recommended to:

1. Configure email notifications to monitor system health and Task activity
2. Enable syslog – see §E.1 (p.126)

Platform Considerations

For further information on platform-specific interoperability considerations, please refer to the appropriate sections of Chapter 5.

3.6 Policy Tuning

Periodically re-assess file distribution and access behavior:

1. Run 'Gather Statistics' Policies
 - Examine reports
2. Examine Server statistics – see §1.4.1 (p.3)
 - For more detail, examine demigrates in file server agent .log files

Consider:

- Are there unexpected peaks in demigration activity?

3.7. SYSTEM UPGRADE

- Are there any file types that should not be migrated?
- Should different rules be applied to different file types?
- Is the Migration Policy migrating data that is regularly accessed?
- Are the Rules aggressive enough or too aggressive?
- What is the data growth rate on primary and secondary storage?
- Are there subtrees on the source file system that should be addressed by separate policies or excluded from the source entirely?

3.7 System Upgrade

When a Moonwalk deployment is upgraded from a previous version, Admin Tools must always be upgraded first, followed by *all* Server components. Any installed plugins will be upgraded automatically during Agent upgrade.

All components must be upgraded to the same version unless otherwise specified.

3.7.1 Upgrade Procedure

1. Run the `Moonwalk Admin Tools.exe` installer
2. Upgrade all Server components (see below)
3. Resolve any warnings displayed on the *'Dashboard'*

3.7.2 Automated Server Upgrade

Where possible, it is advisable to upgrade Server components using the automated upgrade feature by clicking the **Upgrade System** icon on the *'Servers'* page.

The automated process transfers installers to each server and performs the upgrades in parallel to minimize downtime. If a server fails or is offline during the upgrade, manually upgrade it later. Once the automated upgrade procedure is finalized, the *'Servers'* page will update to display the health of the upgraded servers.

Automated upgrade is available for Windows Servers only.

3.7.3 Manual Server Upgrade

Follow the instructions appropriate for the platform of each server as described below. Plugins and configuration will be updated automatically.

Agent for Windows

1. Run `Moonwalk Agent.exe` and follow the instructions
2. Check the AdminCenter *'Servers'* page for warnings

NetApp FPolicy Server

1. Run `Moonwalk NetApp FPolicy Server.exe` and follow the instructions
2. Check the AdminCenter *'Servers'* page for warnings

3.7. SYSTEM UPGRADE

LinkConnect Server

1. Run `Moonwalk LinkConnect Server.exe` and follow the instructions
2. Check the AdminCenter 'Servers' page for warnings

Agent for OES Linux

Planning note: The installer may request a reboot during the following procedure.

If upgrading from version 11.0u2 or earlier:

1. Open a root console
2. `rpm --erase moonwalk_columbia`
3. Install Agent as per §2.2.3 (p.10)

For all other upgrades:

1. Open a root console
2. `rpm -U moonwalk_agent_PLATFORM...x86_64.rpm`
3. Check the AdminCenter 'Servers' page for warnings

Chapter 4

Policy Operation Reference

This chapter describes the various operations that may be performed on selected files by AdminCenter policies.

4.1 Gather Statistics Operation

Requires: Source(s)

Included in Starter Edition: yes

Generate statistics report(s) for file sets at the selected Source(s). Optionally include statistics by file owner. By default, owner statistics are omitted which generally results in a faster policy run. Additionally, rules may be used to specify a subset of files on which to report rather than the whole source.

4.2 Migrate Operation

Requires: Source(s), Rule(s), Destination

Included in Starter Edition: yes

Migrate file data from selected Source(s) to a Destination. Stub files remain at the Source location as placeholders until files are demigrated. File content will be transparently demigrated (returned to primary storage) when accessed by a user or application. Stub files retain the original logical size and file metadata. Files containing no data will not be migrated.

Each Migrate operation will be logged as a Migrate, Remigrate, or Quick-Remigrate.

A Remigrate is the same as a Migrate except it explicitly recognizes that a previous version of the file had been migrated in the past and that stored data pertaining to that previous version is no longer required and so is eligible for removal via a Scrub policy.

A Quick-Remigrate occurs when a file has been demigrated and NOT modified. In this case it is not necessary to retransfer the data to secondary storage so the operation can be performed very quickly. Quick-remigration does **not change the secondary storage location** of the migrated data.

4.3. QUICK-REMIGRATE OPERATION

Optionally, quick-remigration of files demigrated within a specified number of days may be prevented. This option can be used to avoid quick-remigrations occurring in an overly aggressive fashion.

Additionally, this policy may be configured to pause during the globally configured work hours.

If using a capacity-based license, Migrates and Remigrates (but not Quick-Remigrates) consume capacity license quota.

Note: For Sources using a LinkConnect Server, such as Dell EMC Isilon shares, see §4.9 instead.

4.3 Quick-Remigrate Operation

Requires: Source(s), Rule(s)

Included in Starter Edition: yes

Quick-Remigrate demigrated files that do not require data transfer, enabling space to be reclaimed quickly. This operation acts only on files that have not been altered since the last migration.

Optionally, files demigrated within a specified number of days may be prevented. This option can be used to avoid quick-remigrations occurring in an overly aggressive fashion.

Additionally, this policy may be configured to pause during the globally configured work hours.

Capacity license quota is not consumed.

4.4 Scrub Destination Operation

Requires: Destination (non-WORM)

Included in Starter Edition: yes

Remove unnecessary stored file content from a migration destination. This is a maintenance policy that should be scheduled regularly to reclaim space (and license quota if using capacity-based licensing) .

A grace period must be specified which is sufficient to cover the time from when a backup is taken to when the restore and corresponding Post-Restore Revalidate policy would complete. The grace period effectively delays the removal of data sufficiently to accommodate the effects of restoring primary storage from backup to an earlier state.

Use of scrub is usually desirable to maximize storage efficiency. In order to also maximize performance benefits from quick-remigration, it is advisable to schedule migration / quick-remigration policies more frequently than the grace period.

To avoid interactions with migration policies, Scrub tasks are automatically paused while migration-related tasks are in progress.

Scrub Policies may be configured to generate log output only without actually removing files.

Important: Source(s) MUST be backed up within the grace period.

4.5 Post-Restore Revalidate Operation

Requires: Source(s)

Included in Starter Edition: yes

Scan all stubs present on a given Source, revalidating the relationship between the stubs and the corresponding files on secondary storage. This operation is required following a restore from backup and should be performed on the **root** of the restored source volume.

If *only* Write Once Read Many (WORM) destinations are in use, this policy is not required.

Important: This revalidation operation **MUST** be integrated into backup/restore procedures, see §3.4.1 (p.16).

4.6 Demigrate Operation

Requires: Source(s), Rule(s)

Included in Starter Edition: yes

Return migrated file content back to files on the selected Source(s). This is useful when a large batch of files must be demigrated in advance.

Prior to running a Demigrate policy, be sure that there is sufficient primary storage available to accommodate the demigrated data.

This operation may be used with both Migrated and Link-Migrated files.

4.7 Advanced Demigrate Operation

Requires: Source(s), Rule(s)

Included in Starter Edition: yes

Demigrates files with advanced options:

- **Disconnect files from destination** – remove destination information from demigrated files (both files demigrated by this policy and files that have already been demigrated); it will no longer be possible to quick-remigrate these files
- A **Destination Filter** may optionally be specified in order to demigrate/disconnect only files that were migrated to a particular destination

Prior to running an Advanced Demigrate policy, be sure that there is sufficient primary storage available to accommodate the demigrated data.

4.8 Simple Premigrate Operation

Requires: Source(s), Rule(s), Destination

Included in Starter Edition: yes

4.9. LINK-MIGRATE OPERATION

Premigrate file data from selected Source(s) to a Destination in preparation for migration. Files on primary storage will not be converted to stubs until a Migrate or Quick-Remigrate Policy is run. Files containing no data will not be premigrated.

This can assist with:

- a requirement to delay the stubbing process until secondary storage backup or replication has occurred
- reduction of excessive demigrations while still allowing an aggressive Migration Policy.

Premigration is, as the name suggests, intended to be followed by full migration/quick-remigration. If this is not done, a large number of files in the premigrated state may slow down further premigration policies, as the same files are rechecked each time.

By default, files already premigrated to another destination will be skipped when encountered during a premigrate policy.

This policy may also be configured to pause during the globally configured work hours.

If using a capacity-based license, capacity license quota is consumed.

Note: Most deployments will not use this operation, but will use a combination of Migrate and Quick-Remigrate instead.

4.9 Link-Migrate Operation

Requires: Source(s), Rule(s), Destination

Included in Starter Edition: no

For platforms that do not support standard stub-based migration, Link-Migrate file data from selected Source(s) to a Destination.

Files at the source location will be replaced with Moonwalk-encoded links (MigLinks) which allow client applications to transparently read data without returning files to primary storage. If an application attempts to modify a link, the file will be automatically returned to primary storage and then modified in-place. Files containing no data will be skipped by this policy.

MigLinks present the original logical size and file metadata.

Since MigLinks remain links when *read* by client applications, there is no analogue of quick-remigration for link-migrate.

This policy may be configured to pause during the globally configured work hours.

If using a capacity-based license, Link-Migrates consume capacity license quota.

Note: This operation does not support Swarm or CloudScaler Destinations.

4.10 Change Destination Tier Operation

Requires: Source(s), Rule(s), Destination Filter, New Destination

Included in Starter Edition: no

4.11. RETARGET DESTINATION OPERATION

Change migration tier of selected files that are already migrated or link-migrated to a secondary storage destination by copying the secondary storage data to the new Destination and then updating the stubs / MigLinks accordingly. The defunct copy on the original destination will be removed by a subsequent Scrub Policy (scheduled separately and subject to the configured grace period).

This operation is typically used to realize a multi-tier environment, in which files can be aged across storage tiers over time. This is not to be confused with the Retarget Destination operation (§4.11), which caters for the decommissioning of a secondary storage target.

If desired, rules can be used to apply different tiering criteria to different subsets of the data.

If using a capacity-based license, capacity license quota will be transferred to the new destination files – scrubbing the original destination will not recover quota.

This policy may be configured to pause during the globally configured work hours.

Note: Files migrated to WORM destinations cannot be moved to another tier. These files will be skipped.

Note: This operation does not support Swarm or CloudScaler targets for the *new* Destination.

4.11 Retarget Destination Operation

Requires: Source(s), Destination Filter, New Destination

Included in Starter Edition: no

Permanently retarget stubs or MigLinks to a new migration destination. This operation is intended for use when completely decommissioning an old migration destination – the defunct copy of the file content will *not* be removed from the original destination either by this operation or by subsequent Scrub operations.

Any old data that is no longer referenced by stubs or MigLinks will *not* be transferred to the new destination.

This operation does not affect capacity license quota.

Warning: This policy must be run on the root of all volumes that may contain stubs on all servers prior to finally decommissioning the old migration destination. **Re-run the policies** as necessary until there are no more files to retarget.

This policy may be configured to pause during the globally configured work hours.

Note: This operation does not support Swarm or CloudScaler targets for the *new* Destination.

4.12 Ingest Operation

Requires: Source(s), Rule(s), Destination

Included in Starter Edition: yes

Ingest files into a cloud or object store Destination. Original filenames and paths are preserved.

4.13. COPY OPERATION

Optionally, original file metadata – including a user-specified custom-metadata field – can be attached to the destination objects. The original files' security details can also be attached. Please see the relevant section of Chapter 5 for the specifics of how metadata is stored on a given destination.

An Ingest policy must include a '*Collision Behavior*' option to specify the action to be taken when ingesting files that would overwrite existing objects at the destination. Supported behaviors are:

Collision Behavior	Description
Overwrite existing file	Overwrites objects unconditionally
Always append timestamp	Appends an ISO8601-compatible timestamp suffix to ALL object names, e.g. <code>file.txt_20200401T115959Z</code>

Since partially ingested datasets are not typically useful, the policy will perform a configurable number of attempts to ingest each object. Such retries are appropriately logged for troubleshooting.

Optionally, for data that will no longer be required on primary storage after ingestion, the original files may be deleted on a file-by-file basis as each file is successfully ingested.

A Content-Disposition header can be automatically added to ingested HTTP objects such that user download via a browser will preserve the original filename (e.g. `file.txt` without any suffixes).

Where security details are to be attached to ingested objects, the format is source-platform specific. For Windows files, a Security Descriptor (owner, group and ACLs) is recorded in Microsoft SDDL format for each object. For NFS sources, UID, GID and octal permissions are recorded as separate fields. For OES Linux NSS files, the IRM and Trustee Grants are encoded in a string format.

An upper limit may be specified to prevent very large security details field values being attached to an object. Values exceeding this limit will be replaced with the supplied default value (or omitted entirely if a default is not provided). SDDL default values must be prepended with `'win:'`.

Note: files should not usually be migrated prior to ingestion. The ingest process will demigrate any stubs as necessary to retrieve the data for ingest.

4.13 Copy Operation

Requires: Source(s), Rule(s), Destination

Included in Starter Edition: no

Copy files from Source(s) to a filesystem Destination.

By default, when a migrated stub is copied, a full file (not a stub) will be created at the Copy Destination without demigrating the file stub at the Source. However, there is an option to force demigration of the stub at the Source during the copy if required.

In the case of Link-Migrated files, source files remain as links following the operation.

Note: where Source and Destination use radically different filesystems, some filenames may not be representable at the Destination and will be uncopyable. Similarly, Source filenames that are not considered unique by the Destination filesystem – e.g. differing only by case – will conflict with each other. Such conflicts may be addressed by using the '*rename*' overwrite option.

4.14 Move Operation

Requires: Source(s), Rule(s), Destination

Included in Starter Edition: no

Move files from Source(s) to a filesystem Destination.

If possible, the Move Operation will move migrated stubs without demigration – a stub-move – creating a stub at the Move Destination. A stub-move will be performed, rather than a full file move if:

- The Destination supports migration
- The Agent at the Destination is not a Gateway

Moving a link-migrated file always results in a full file move.

Optionally, a Move policy can be configured to force demigration of stubs during transit if desired. However, in the case of Link-Migrated files, destination files are always full files, not links following the operation.

Note: where Source and Destination use radically different filesystems, some filenames may not be representable at the Destination and will be uncopyable. Similarly, Source filenames that are not considered unique by the Destination filesystem – e.g. differing only by case – will conflict with each other. Such conflicts may be addressed by using the *'rename'* overwrite option.

4.15 Additional Copy and Move Options

- *'Path'* options:
 - **preserve** indicates that the relative path of each file, from the root of its source, should be preserved at the destination
 - **prepend server and volume name** prepends an extra directory component such as `server_volname` to the path
 - **skip empty directories** skips the creation of directories containing no matching files on the Source
 - **preserve directory metadata** preserves metadata for directories as well as files
- *'Metadata'* options:
 - **preserve timestamps** preserves time and date information
 - **preserve attribute flags** preserves flags such as 'Read-Only', 'Hidden', etc.
 - **preserve unix ownership and permissions** preserves owner, group and permissions on NFS (this option must first be enabled on the *'Settings'* Page)
- *'Overwrite'* options:
 - **always** – a file moved/copied from a Source will always overwrite any identically named file already existing at the corresponding location on the Destination
 - **never** – never overwrites existing files at the destination
 - **rename** – clashing filenames are disambiguated by renaming the new file. For example, if a file named `letter.doc` is copied to a Destination where a file with this name already exists, the new file would be renamed to `letter [1] .doc` (or, if that too exists, `letter [2] .doc`, and so forth)

4.16. CREATE RECOVERY FILE FROM SOURCE OPERATION

- **if newer** – only overwrites the file if the Source file is newer than the Destination file

4.16 Create Recovery File From Source Operation

Requires: Source(s), Rule(s)

Included in Starter Edition: no

Generate a disaster recovery file for Moonwalk DrTool by analyzing files at the selected Source(s). DrTool can use the generated file(s) to recover or update source files.

Note: Recovery files generated from *Source* will account for renames.

4.17 Create Recovery File From Destination Operation

Requires: Destination

Included in Starter Edition: no

Generate a disaster recovery file for Moonwalk DrTool by analyzing files at the selected Destination without reference to the associated primary storage files.

Note: Recovery files from *Destination* may not account for renames.

Important: It is strongly recommended to use '*Create Recovery File From Source*' in preference where possible.

4.18 Delete Operation

Requires: Source(s), Rule(s)

Included in Starter Edition: yes

Delete files from Source(s).

Important: Deletion of files cannot be undone.

4.19 Erase Cached Data Operation

Requires: Source(s), Rule(s)

Included in Starter Edition: yes

Erases cached data associated with files by the *Partial Demigrate* feature (NetApp-Sources only).

Important: The Erase Cached Data operation is not enabled by default. It must be enabled in '*Settings*' → '*Additional Options*'.

Chapter 5

Source and Destination Reference

The following pages describe the characteristics of the Sources and Destinations supported by Moonwalk. Planning, setup, usage and maintenance considerations are outlined for each storage platform.

IMPORTANT: Read any relevant sections of this chapter prior to deploying Moonwalk in a production environment.

5.1 Microsoft Windows

5.1.1 Migration Support

Windows NTFS volumes may be used as migration sources. On Windows Server 2016 and above, ReFS volumes are also supported as migration sources.

Windows stub files can be identified by the 'O' (Offline) attribute in Explorer. Depending on the version of Windows, files with this flag may be displayed with an overlay icon.

Windows volumes may also be used as Destinations (not supported by *Starter Edition* licenses).

Note: If it is not possible to install the Moonwalk Agent directly on the file server, see §5.2 for an alternative solution using Link-Migration.

5.1.2 Planning

Prerequisites

- A license that includes an appropriate entitlement for Windows

When creating a production deployment plan, please refer to §3.5 (p.18).

Cluster Support

Clustered volumes managed by Windows failover clusters are supported. However, the Cluster Shared Volume (CSVFS) feature is NOT supported. As a result, on Windows Server 2012 and above, when configuring a 'File Server' role in the Failover Cluster Manager, 'File Server for general use' is the only supported File Server Type. The 'Scale-Out File Server for application data' File Server Type is NOT supported.

When using clustered volumes in Moonwalk URIs, ensure that the resource FQDN appropriate to the volume is specified rather than the FQDN of any individual node.

5.1.3 Setup

Installation

See Installing Agent for Windows §2.2.2 (p.10)

5.1.4 Usage

URI Format

win://{servername}/{drive letter}/{path}

Where:

- `servername` – Server FQDN or Windows Failover File Server Resource FQDN

5.1. MICROSOFT WINDOWS

- `drive letter` – Windows volume drive letter

Examples:

```
win://fs1.example.com/d/projects
```

```
win://fs2.example.com/e/
```

Note: Share names and mapped drives are not supported. To access files over SMB, see §5.22.

5.1.5 Interoperability

This section describes Windows-specific considerations only and should be read in conjunction with §3.5 (p.18).

Microsoft Storage Replica

Moonwalk supports Microsoft Storage Replica.

If Storage Replica is configured for *asynchronous* replication, a disaster failover effectively reverts the volume to a previous point in time. As such, this kind of failover is directly equivalent to a volume restore operation (albeit to a very recent state).

As with any restore, a Post-Restore Revalidate Policy (see §4.5 (p.24)) should be run across the restored volume within the scrub grace period window. This will ensure correct operation of any future scrub policies by accounting for discrepancies between the demigration state of the files on the (failed) replication source volume and the replication destination volume.

Important: integrate this process into your recovery procedures prior to production deployment of asynchronous storage replication.

Microsoft DFS Namespaces (DFSN)

DFSN is supported. Moonwalk Sources must be configured to access volumes on individual servers directly rather than through a DFS namespace. Users and applications may continue to access files and stubs via DFS namespaces as normal.

Microsoft DFS Replication (DFSR)

DFSR is supported for:

- Windows Server 2019
- Windows Server 2016
- Windows Server 2012 R2

Agents must be installed (selecting the *migration* role during installation) on **EACH** member server of a DFS Replication Group prior to running migration tasks on any of the group's Replication Folders.

If adding a new member server to an existing Replication Group where Moonwalk is already in use, Agent must be installed on the new server first.

5.1. MICROSOFT WINDOWS

When running policies on a Replicated Folder, sources should be defined such that each policy acts upon **only one** replica. DFSR will replicate the changes to the other members as usual.

Read-only (one-way) replicated folders are NOT supported. However, read-only SMB shares can be used to prevent users from writing to a particular replica as an alternative.

Due to the way DFSR is implemented, care should be taken to avoid *writing* to stub files that are being concurrently accessed from another replica.

In the rare event that DFSR-replicated data is restored to a member from backup, ensure that DFSR services on all members are running and that replication is **fully up-to-date** (check for the DFSR 'finished initial replication' Windows Event Log message), then run a Post-Restore Revalidate Policy using the same source used for migration.

Note: If using a capacity-based license, no additional capacity license quota is consumed when stubs are replicated by DFSR.

Retiring a DFSR Replica

Retiring a replica effectively creates two *independent* copies of each stub, without updating secondary storage. To avoid any potential loss of data:

1. Delete the contents of the retired replica (preferably by formatting the disk, or at least disable Stub Deletion Monitoring during the deletion)
2. Run a Post-Restore Revalidate Policy on the remaining copy of the data

If it is strictly necessary to keep both, now independent, copies of the data and stubs, then run a Post-Restore Revalidate Policy on **both** copies separately (not concurrently).

Preseeding a DFSR Replicated Folder Using Robocopy

The most common use of Robocopy with Moonwalk stubs is to preseed or stage initial synchronization. When performing such a pre seeding operation:

- for new Replicated Folders, ensure that the 'Primary member' is set to be the original server, not the preseeded copy
- both servers must have Agent installed **before** pre seeding
- add a "Process Exclusion" to Windows Defender for `robocopy.exe` (allow a while for the setting to take effect)
- on the source server, preseed by running robocopy with the `/b` flag (to copy stubs as-is to the new server)
- once pre seeding is complete and replication is **fully up-to-date** (check for the DFSR 'finished initial replication' Windows Event Log message), it is recommended to run a Post-Restore Revalidate Policy on the original Moonwalk Source

Note: If the process above is aborted, be sure to delete all preseeded files and stubs (preferably by formatting the disk, or at least disable Stub Deletion Monitoring during the deletion) and then run a Post-Restore Revalidate Policy on the original Moonwalk Source.

Robocopy (Other Uses)

Robocopy will, by default, demigrate stubs as they are copied. This is the same behavior as Explorer copy-paste, xcopy etc..

Robocopy with the `/b` flag (backup mode – must be performed as an administrator) will copy stubs as-is.

Robocopy /b is not recommended. If stubs *are* copied in this fashion, the following must be considered:

- for a copy from one server to another, both servers must have Moonwalk Agent installed
- this operation is essentially a backup and restore in one step, and thus inappropriately duplicates stubs which are intended to be unique
 - after the duplication, one copy of the stubs should be deleted immediately
 - run a Post-Restore Revalidate policy on the remaining copy
 - this process will render the corresponding secondary storage files non-scrubbable, even after they are demigrated
- to prevent Windows Defender triggering demigrations when the stubs are accessed in this fashion:
 - always run the robocopy from the source end (the file server with the stubs)
 - add a “Process Exclusion” to Windows Defender for `robocopy.exe` (allow a while for the setting to take effect)

Windows Data Deduplication

If a Windows source server is configured to use migration policies and Windows Data Deduplication, it should be noted that a given file can either be deduplicated or migrated, but not both at the same time. Moonwalk migration policies will automatically skip files that are already deduplicated. Similarly, Windows will skip Moonwalk stubs when deduplicating.

When using both technologies, it is recommended to configure Data Deduplication and Migration based on file type such that the most efficacious strategy is chosen for each type of file.

Note: Microsoft’s legacy Single Instance Storage (SIS) feature is not supported. Do not use SIS on the same server as Moonwalk Agent.

Windows Shadow Copy

Windows Shadow Copy – also known as Volume Snapshot Service (VSS) – allows previous versions of files to be restored, e.g. from Windows Explorer. This mechanism cannot be used to restore a stub. Restore stubs from backup instead – see §3.4 (p.16).

To Copy or Ingest from a VSS shadow copy, the `smb://` scheme must be used for the Moonwalk Source, e.g.

```
smb://<gateway>/<server>/share1/@GMT-2019.03.13-07.20.29/path/
```

See §5.22 for more information about the `smb://` scheme.

5.1.6 Behavioral Notes

Junction Points & Symlinks

With the exception of volume mount points, junction points will be skipped during traversal of the file system. Symlinks are also skipped. This ensures that files are not seen – and thus acted upon – multiple times during a single execution of a given policy. If it is intended that a policy should apply to files within a directory referred to by a junction point, either ensure that the Source encompasses the real location at the junction point's destination, or specify the junction point itself as the Source.

Mount-DiskImage

On Windows 8 or above, VHD and ISO images may be mounted as normal drives using the PowerShell Mount-DiskImage cmdlet. This functionality can also be accessed via the Explorer context menu for an image file.

A known limitation of this cmdlet is that it does not permit *sparse* files to be mounted (see Microsoft KB2993573). Since migrated image files are always sparse, they must be demigrated prior to mounting. This can be achieved either by copying the file or by removing the sparse flag with the following command:

```
fsutil sparse setflag <file_name> 0
```

5.1.7 Stub Deletion Monitoring

On Windows, the Agent can monitor stub deletions to identify secondary storage files that are no longer referenced in order to maximize the usefulness of Scrub Policies. This feature extends not only to stubs that are directly deleted by the user, but also to other cases of stub file destruction such as overwriting a stub or renaming a different file over the top of a stub.

As of Moonwalk 12.1u2, Stub Deletion Monitoring is disabled by default. To enable it, please refer to §E.2 (p.126).

5.2 Microsoft Windows via LinkConnect Server

5.2.1 Link-Migration Support

This section details the configuration of a Moonwalk LinkConnect Server to enable Link-Migration of files from Windows Server SMB shares. This option should be used when it is not possible to install Moonwalk Agent directly on the Windows file server in question. For other cases – where Agent *can* be installed on the server – please refer to §5.1.

Refer to §4.2 (p.22) and §4.9 (p.25) for details of the Migrate and Link-Migrate operations respectively.

Link-Migration works by pairing a Windows SMB share with a corresponding LinkConnect Cache Share. Typically a top-level share on each Windows file server volume is mapped to a unique share (or subdivision) on a LinkConnect Server. Multiple file server shares may use Cache Shares / subdivisions on the same LinkConnect Server if desired.

Once this configuration is completed, Link-Migrate policies convert files on the source Windows Server SMB share to links pointing to the destination files via the LinkConnect Cache Share, according to configured rules.

Link-Migrated files can be identified by the 'O' (Offline) attribute in Explorer. Depending on the version of Windows, files with this flag may be displayed with an overlay icon.

5.2.2 Planning

Prerequisites

- An NTFS Cache Volume of at least 1TB – see §2.4 (p.11)
- A Moonwalk license that includes an entitlement for LinkConnect Server.
- A supported secondary storage destination (any Moonwalk destination except for Swarm or CloudScaler)

When creating a production deployment plan, please refer to §3.5 (p.18).

File Server System Requirements

- Windows Server 2016 or higher
- The server must NOT have the Active Directory Domain Services role

Client Requirements

Windows clients require a supported 64-bit Windows operating system:

- Windows 10
- Windows Server 2019
- Windows Server 2016
- Windows Server 2012 R2

In order to access link-migrated files, the LinkConnect Client Driver must be installed on each client machine – see §2.5 (p.12).

5.2. MICROSOFT WINDOWS VIA LINKCONNECT SERVER

Network

Place the Moonwalk LinkConnect Server on the same subnet and same switch as the corresponding Windows file server(s) to minimize latency.

Additionally, the LinkConnect Server **must** be joined to the same domain as the Windows file server and the Windows client machines.

Antivirus Considerations

Ensure that Windows Defender or any other antivirus product installed on the LinkConnect Server is configured to **omit** scanning/screening on the LinkConnect Cache Volume **and** any Windows file server SMB shares.

High-Availability for LinkConnect Server

Consider whether High-Availability (HA) is required in your environment (either now *or in the future*). If so, LinkConnect Servers must be installed in a DFSN configuration from the outset.

LinkConnect Cache Shares are configured for HA by exposing the share name at the domain level using DFSN. If not using HA, it is possible to use either a simple share on a standalone server, or a share exposed at the domain level using DFSN. The latter is always recommended to allow transition to an HA configuration in the future.

Regular Maintenance Activity

Each configured MigLink source will be periodically scanned to perform maintenance tasks such as MigLink ACL propagation and Link Deletion Monitoring (see below).

In an HA configuration, this scanning activity will be performed by a single caretaker node. The current caretaker can be seen on the AdminCenter Servers page. When not configured for HA, a LinkConnect Server always performs the caretaker role.

Link Deletion Monitoring

Similarly to the Stub Deletion Monitoring feature provided by Moonwalk Agents on Windows, Link Deletion Monitoring (LDM) identifies secondary storage files that are no longer referenced in order to facilitate recovery of storage space by Scrub Policies. This feature extends not only to MigLinks that are demigrated or directly deleted by the user, but also to other cases such as overwriting a MigLink or renaming a different file over the top of a MigLink.

Unlike SDM, LDM requires a number of maintenance scans to determine that a given secondary storage file is no longer referenced. It should be noted that interrupting the maintenance process (e.g. by restarting the caretaker node or transitioning the caretaker role) will delay the detection of unreferenced secondary storage. For optimal and timely storage space recovery, ensure that LinkConnect Servers can run uninterrupted for extended periods.

5.2. MICROSOFT WINDOWS VIA LINKCONNECT SERVER

Warning: in order to avoid LDM incorrectly identifying files as deleted – leading to unwanted data loss during Scrub – it is critical to ensure that users cannot *move/rename* MigLinks out of the scanned portion of the directory tree within the filesystem. This can be achieved by always creating the share used for your ‘*miglinkSource*’ at the root of the filesystem. An additional share may be created solely for this purpose.

To utilize LDM, it must first be enabled on a per-share basis.

5.2.3 Setup

Create a LinkConnect User

Provision a user on the Windows domain for the exclusive use of your LinkConnect service(s). This user does *not* need to be a member of Domain Admins.

Configure Windows File Server

On the file server:

1. Add the LinkConnect User to the the *local* Administrators group
2. Add ‘*Full Control*’ permissions for this user to each share
 - be sure to configure the share, not the folder permissions

Installation

On each LinkConnect Server machine:

1. Ensure that the user created above has the ‘Log on as a service’ privilege
2. Run the `Moonwalk LinkConnect Server.exe`
3. Follow the prompts to complete the installation
4. Follow the instructions to activate the installation as a standalone server
 - the Servers page will report that the server is unconfigured

Cache Share Creation

On your cache volume (e.g. X:\), navigate to
`X:\1bf8ce99-8c8a-4092-9c98-2b9c850c57a1\shares.`

To create each Cache Share:

- Create a new folder with the desired share name
- Right click → Properties → Sharing → Advanced Sharing...
- Tick ‘*Share this folder*’
- Share name **must** match the folder name exactly (including case)
- Permissions:
 - Everyone: Allow ‘*Read*’ only
 - No other permissions

Service Configuration

On the AdminCenter 'Servers' page, edit the configuration of the LinkConnect Server. In the 'Advanced Options' box, add the following options:

```
linkconnect.config.linkConnectAlias=ALIAS_FQDN
```

where ALIAS_FQDN is either the FQDN of the LinkConnect Server (standalone mode), or of the DFSN domain (standalone or high-availability).

For each share mapping, add:

```
linkconnect.config.MAPPING_NUMBER.miglinkSourceType=win
linkconnect.config.MAPPING_NUMBER.miglinkSource=WIN_FQDN/WIN_SHARE
linkconnect.config.MAPPING_NUMBER.linkConnectTarget=CACHE_SHARE\SUBDIV
linkconnect.config.MAPPING_NUMBER.key=SECRET_KEY
linkconnect.config.MAPPING_NUMBER.linkDeletionMonitoring.enabled=<bool>
```

where:

- miglinkSourceType must be set to exactly **win**
- MAPPING_NUMBER starts at 1 for the first share mapping in this file – mappings must be numbered consecutively
- WIN_FQDN/WIN_SHARE describes the file server share to be mapped
- CACHE_SHARE is a LinkConnect Cache Share name (created above)
 - this value is CASE-SENSITIVE
- SUBDIV **must** be the single decimal digit 1
- SECRET_KEY is at least 40 ASCII characters – this key protects against counterfeit link creation
 - recommendation: use a password generator with 64 'All Chars'
- linkDeletionMonitoring.enabled may be set to **true** or **false** to enable/disable Link Deletion Monitoring on this share – **see warning above**

If clients will access the storage via nested sub-shares rather than only the top-level configured MigLink Source share, the known sub-shares should be added as follows:

```
linkconnect.config.MAPPING_NUMBER.knownSubShares=share1,share2
```

This list of sub-shares can be updated later as more subdirectories are shared. Where MigLink access occurs on unexpected shares, warnings will be written to the LinkConnect agent.log.

Save the configuration and restart the Moonwalk Agent service.

Important: Refer to §3.3.2 (p.15) to ensure that the configuration on this LinkConnect Server is included in your backup. If the LinkConnect Server needs to be rebuilt, the secret key will be required to enable previously link-migrated files to be securely accessed.

DFSN Configuration

If DFSN is to be used (even if not yet using HA), namespaces and folders must be configured as follows:

1. Add a DFSN namespace:
 - the namespace **must not** be hosted on a LinkConnect Server machine

5.2. MICROSOFT WINDOWS VIA LINKCONNECT SERVER

- the namespace *name* **must** match the LinkConnect Cache Share name exactly (including case)
 - the namespace **must** be *'Domain-based'*
2. Add a folder to the namespace:
- folder name must be of the form: SUBDIV_MwC1C_1 e.g. 1_MwC1C_1
 - Add folder target:
 - `\\SERVER\CACHE_SHARE\SUBDIV_MwC1C_1`
 - where SERVER is a LinkConnect Server which exports CACHE_SHARE
 - where CACHE_SHARE matches the namespace name exactly (including case)
 - where SUBDIV_MwC1C_1 matches the new folder name exactly (including case)
 - the folder target will already exist – it was created by the LinkConnect Server in the previous section
 - **DO NOT** enable replication
 - Add additional targets to the same folder for each other LinkConnect Server in the HA group

For example, `\\example.com\CacheA\1_MwC1C_1` may refer to both of the following locations:

```
\\server1.example.com\CacheA\1_MwC1C_1
\\server2.example.com\CacheA\1_MwC1C_1 (optional 2nd server)
```

Recovery of Lost Secret Key

In cases where the keys have been lost and a Moonwalk LinkConnect Server needs to be rebuilt, it is possible to temporarily disable the Counterfeit Link Protection (CLP) and re-sign all links with a new key. To enable this behavior, recreate the configuration as above (with a new secret key), and add a line similar to the following:

```
linkconnect.config.disableSignatureSecurityUntil=2020-04-14T01:00:00Z
```

Regular scanning of the configured share mapping will update the links present in all scanned links to use the new key, and any user-generated access to these links will function without verifying the signatures **until the configured cutoff time**, specified as Zulu Time (GMT). For a large system, it may be necessary to allow several days before the cutoff, to enable key update to complete. Users may continue to access the system during this period.

5.2.4 Usage

URI format

```
smb://{server}/{nas}/{share}/[/{path}]
```

Where:

- *server* – FQDN of a LinkConnect Server that is configured to support the file server share
- *nas* – Windows file server FQDN
- *share* – Windows file server SMB share

5.2. MICROSOFT WINDOWS VIA LINKCONNECT SERVER

- `path` – path within the share

Example:

```
smb://link.example.com/winserver.example.com/pub/projects
```

5.2.5 Known Issues

Service Restart Delay

Depending on the cache size, dataset and workload characteristics, the Moonwalk Agent service on the LinkConnect Server may take some time to perform cache cleanup during service restart. During this time, the Moonwalk AdminCenter will not be able to connect to retrieve status information.

5.3 Micro Focus Open Enterprise Server

5.3.1 Migration Support

Micro Focus Open Enterprise Server (OES Linux) NSS volumes may be used as migration sources.

NSS stub files are distinguished by the NSS Migration flag. When viewed on a Windows client via SMB or NCP, the 'O' (Offline) attribute is set in Explorer. Depending on the version of Windows, files with this flag may be displayed with an overlay icon.

NSS volumes may also be used as Destinations (not supported by *Starter Edition* licenses).

5.3.2 Planning

Prerequisites

- Ensure cluster resource names that will be used have DNS aliases to names without underscores (_) since underscores are not valid DNS characters and therefore not allowed (e.g. for MY_CLUSTER_POOL create DNS alias MY-CLUSTER-POOL)
- A license that includes an appropriate entitlement for OES Linux

When creating a production deployment plan, please refer to §3.5 (p.18).

5.3.3 Setup

Installation

See Installing Agent for Micro Focus OES Linux §2.2.3 (p.10)

5.3.4 Usage

URI Format

```
nss://{servername}/{volumename}/[{path}]
```

Where:

- `servername` – Server FQDN or Clustered Pool Resource FQDN
- `volumename` – NSS volume name

Note: When using clusters, ensure *Cluster Pool Resource* FQDNs are used in Moonwalk URIs. These will continue to refer to the correct volumes during cluster failover.

Examples:

```
nss://fs1.example.com/DATA/projects  
nss://clust-pool-1.example.com/CLUSTVOL1/
```

5.3. MICRO FOCUS OPEN ENTERPRISE SERVER

Legacy URIs

Older versions of Moonwalk provided NSS support via the `nove11://` URI scheme. Sources and Destinations using these URIs will continue to work after upgrade and should NOT be updated to use the `nss://` scheme. New sources may use either scheme.

5.4 NetApp Filer

This section describes support for NetApp Filers.

5.4.1 Migration Support

Migration support for sources on NetApp Vservers (Storage Virtual Machines) is provided via NetApp FPolicy. This requires the use of a Moonwalk FPolicy Server. Client demigrations can be triggered via SMB or NFS client access.

Please note that NetApp Filers currently support FPolicy for Vservers with FlexVol volumes but not Infinite volumes.

When accessed via SMB on a Windows client, NetApp stub files can be identified by the 'O' (Offline) attribute in Explorer. Files with this flag may be displayed with an overlay icon. The icon may vary depending on the version of Windows on the client workstation.

Note: The `netapp://` scheme described in this section cannot be used in a migration *destination*. To migrate *to* a NetApp filer, it is recommended to use NFS (see also §5.21).

5.4.2 Planning

Prerequisites

- NetApp Filer(s) must be licensed for the particular protocol(s) to be used (FPolicy requires a CIFS license)
- A Moonwalk license that includes an entitlement for NetApp FPolicy Server

Moonwalk FPolicy Servers require **EXCLUSIVE** use of SMB connections to their associated NetApp Vservers. This means Explorer windows must not be opened, drives must not be mapped, nor should any UNC paths to the filer be accessed from the FPolicy Server machine. Failure to observe this restriction will result in unpredictable FPolicy disconnections and interrupted service.

When creating a production deployment plan, please refer to §3.5 (p.18).

Filer System Requirements

Moonwalk FPolicy Server requires that the Filer is running:

- Data ONTAP version 9.x

Network

Each FPolicy Server should have exactly one IP address.

Place the FPolicy Servers on the same subnet and same switch as their corresponding Vservers to minimize latency.

5.4. NETAPP FILER

Antivirus Considerations

Ensure that Windows Defender or any other antivirus product installed on FPolicy Server machines is configured to **omit** scanning/screening NetApp shares.

Antivirus access to NetApp files will interfere with the correct operation of the FPolicy Server software. Antivirus protection should still be provided on client machines and/or the NetApp Vservers themselves as normal.

High-Availability for FPolicy Servers

It is strongly recommended to install Moonwalk FPolicy Servers in a High-Availability configuration. This configuration requires the installation of Moonwalk FPolicy Server on a group of machines which are addressed by a single FQDN. This provides High-Availability for migration and demigration operations on the associated Vservers.

Typically a pair of FPolicy Servers operating in HA will service all of the Vservers on a NetApp cluster.

Note: The servers that form the High-Availability FPolicy Server configuration must **not** be members of a Windows failover cluster.

DNS Configuration

All Active Directory Servers, Moonwalk FPolicy Servers, and NetApp Filers, **must** have both forward **and** reverse records in DNS.

All hostnames used in Filer and FPolicy Server configuration must be FQDNs.

5.4.3 Setup

Setup Parameters

Before starting the installation the following parameters must be considered:

- Management LIF IP Address: the address for management access to the **Vserver** (not to be confused with cluster or node management addresses)
- CIFS Privileged User: a domain user for the exclusive use of FPolicy

Preparing Vserver Management Access

For each Vserver, ensure that 'Management Access' is allowed for at least one LIF. Check the LIF in OnCommand System Manager - if Management Access is not enabled, either add access to an existing LIF or create a new LIF just for Management Access.

Management authentication may be configured to use either passwords or client certificates. Management connections may be secured via TLS – this is mandatory when using certificate-based authentication.

For password-based authentication:

5.4. NETAPP FILER

1. Select the Vserver in OnCommand System Manager and go to Configuration → Security → Users
2. Add a user for Application 'ontapi' with Role 'vsadmin'
3. Record the username and password for later use on the 'Management' tab in Moonwalk NetApp Cluster-mode Config

Alternatively, for certificate-based authentication:

1. Create a client certificate with common name <Username>
2. Open a command line session to the **cluster** management address
3. Upload the CA Certificate (or the client certificate itself if self-signed):
 - (a) `security certificate install -type client-ca -vserver <vserver-name>`
 - (b) Paste the contents of the CA Certificate at the prompt
4. `security login create -username <Username> -application ontapi -authmethod cert -role vsadmin -vserver <vserver-name>`

Configuring CIFS Privileged Data Access

If it has not already been created, create the CIFS Privileged User on the domain. Each FPolicy Server will use the same CIFS Privileged User for all Vservers that it will manage.

In OnCommand System Manager:

1. Navigate to the Vserver
2. Create a new local 'Windows' group with ALL available privileges
3. Add the CIFS Privileged User to this group
4. Allow a few minutes for the change to take effect (or FPolicy Server operations may fail with access denied errors)

Installation

On each FPolicy Server machine:

1. Close any SMB sessions open to Vserver(s) before proceeding
2. Ensure the CIFS Privileged User has the 'Log on as a service' privilege
3. Run the Moonwalk NetApp FPolicy Server.exe
4. Follow the prompts to complete the installation
5. Follow the instructions to activate the installation as either a standalone server or High-Availability Moonwalk FPolicy Server

Installing 'Moonwalk NetApp Cluster-mode Config'

- Run the installer:
Moonwalk NetApp Cluster-mode Config.exe

5.4. NETAPP FILER

Configuring Components

Run Moonwalk NetApp Cluster-mode Config.

On the 'FPolicy Config' tab:

- Enter the FQDN used to register the FPolicy Server(s) in AdminCenter
- Enter the CIFS Privileged User

On the 'Management' tab:

- Provide the credentials for management access (see above)

On the 'Vservers' tab:

- Click **Add...**
- Enter the FQDN of the Vserver's Data Access LIF
- Optionally, enter the FQDN of a different LIF for Vserver Management
- If using TLS for Management, click **Get Server CA**
- Click **Apply to Filer**

Once configuration is complete, click **Save**.

Apply Configuration to FPolicy Servers

1. Ensure the `netapp_clustered.cfg` file has been copied to the correct location on all FPolicy Server machines
 - `C:\Program Files\Moonwalk\data\Agent\netapp_clustered.cfg`
2. Restart the Moonwalk Agent service on each machine

5.4.4 Usage

URI Format

`netapp://{FPolicy Server}/{NetApp Vserver}/{SMB Share}/[/{path}]`

Where:

- `FPolicy Server` – FQDN alias that points to all Moonwalk FPolicy Servers for the given Vserver
- `NetApp Vserver` – FQDN of the Vserver's Data Access LIF
- `SMB Share` – NetApp SMB share name

Example:

`netapp://fpol-svrs.example.com/vs1.example.com/data/`

Note: The chosen SMB share must be configured to **Hide** symbolic links. If symbolic link support is required for other SMB clients, create a separate share just for Moonwalk traversal that does hide links.

5.4.5 Snapshot Restore

Volume Restore

After an entire volume containing stubs is restored from snapshot, a Post-Restore Revalidate Policy must be run, as per the restore procedure described in §3.4 (p.16).

Individual Stub Restore

Users cannot perform self-service restoration of *stubs*. However, an administrator may restore specific stubs or sets of stubs from snapshots by following the procedure outlined below. Be sure to provide this procedure to all administrators.

IMPORTANT: The following instructions mandate the use of Robocopy specifically. Other tools, such as Windows Explorer copy or the 'Restore' function in the Previous versions dialog, WILL NOT correctly restore stubs.

To restore one or more stubs from a snapshot-folder like:

```
\\<filer>\<share>\~snapshot\<snapshot-name>\<path>
```

to a restore folder on the *same Filer* like:

```
\\<filer>\<share>\<restore-path>
```

perform the following steps:

1. Go to an FPolicy Server machine
2. Open a command window
3. `robocopy <snapshot-folder> <folder> [<filename>...] [/b]`
4. On a client machine (**NOT** the FPolicy Server), open **all** of the restored file(s) or demigrate them using a Demigrate Policy
 - Check that the file(s) have demigrated correctly

IMPORTANT: Until the demigration above is performed, the restored stub(s) may occupy space for the full size of the file.

As with any other Moonwalk restore procedure, be sure to run a Post-Restore Revalidate Policy across the volume before the next Scrub – see §3.4 (p.16).

5.4.6 Interoperability

NDMP Backup

NDMP Backup products require ONTAP 9.2+ for interoperability with Moonwalk.

Robocopy

Except when following the procedure in §5.4.5, Robocopy **must not** be used with the `/b` (backup mode) switch when copying Moonwalk NetApp stubs.

When in backup mode, robocopy attempts to copy stub files as-is rather than demigrating them as they are read. This behavior is not supported.

5.4. NETAPP FILER

Note: The `/b` switch requires Administrator privilege – it is not available to normal users.

5.4.7 Behavioral Notes

Unix Symbolic Links

Unix Symbolic links (also known as symlinks or softlinks) may be created on a Filer via an NFS mount. Symbolic links will not be seen during Moonwalk Policy traversal of a NetApp file system (since only shares which hide symbolic links are supported for traversal). If it is intended that a policy should apply to files within a folder referred to by a symbolic link, ensure that the Source encompasses the real location at the link's destination. A Source URI may NOT point to a symbolic link – use the real folder that the link points to instead.

Client-initiated demigrations via symbolic links will operate as expected.

QTree and User Quotas

NetApp QTree and user quotas are measured in terms of *logical* file size. Thus, migrating files has no effect on quota usage.

Snapshot Traversal

Moonwalk will automatically skip snapshot directories when traversing shares using the `netapp` scheme.

5.4.8 Skipping Sparse Files

It is often undesirable to migrate files that are highly sparse since sparseness is not preserved by the migration process.

To enable sparse files to be skipped during migration policies, tick *'Settings'* → *'Additional Options'* → *'Enable sparse file skipping'* in AdminCenter.

Skipping sparse files may then be configured per migration policy. On the *'Policy Details'* page for Migrate and Simple Premigrate operations, tick *'skip files more than 0% sparse'* and adjust the percentage as required using the drop-down box.

5.4.9 Advanced Configuration

Alternative Engine IP Addresses

Alternative engine IP addresses may be provided on the NetApp Cluster-mode Config *'Advanced'* tab if filer communication is to be performed on a different IP address than that used for AdminCenter to FPolicy Server communication. This allows each node to have two IP addresses. Care must be taken that ALL communication – in both directions – between filer and FPolicy Server node occurs using the **engine** address.

5.4. NETAPP FILER

Ordinarily, one IP address per server is sufficient. Contact Moonwalk Support if an advanced network configuration is required.

Cache First Block

When migrating files, the first block of the file may optionally be cached. This allows small reads to file headers to be completed immediately, without accessing secondary storage. By default this feature is disabled. This feature may be enabled on the 'Advanced' tab. The 'Prefix size' field allows the amount cached on disk after a migration to be tuned.

5.4.10 Troubleshooting

Troubleshooting Management Login

- Open a command line session to the **cluster** management address
- `security login show -vserver <vserver-name>`
 - There should be an entry for the expected user for application 'ontapi' with role 'vsadmin'

Troubleshooting TLS Management Access

- Open a command line session to the **cluster** management address
- `vserver context -vserver <vserver-name>`
- `security certificate show`
 - There should be a 'server' certificate for the Vserver management FQDN (NOT the bare hostname)
 - If using certificate-based authentication, there should be a 'client-ca' entry
- `security ssl show`
 - There should be an enabled entry for the Vserver management FQDN (NOT the bare hostname)

Troubleshooting Vserver Configuration

Vserver configuration can be validated using Moonwalk NetApp Cluster-mode Config.

- Open the `netapp_clustered.cfg` in NetApp Cluster-mode Config
- Go to the 'Vservers' tab
- Select a Vserver
- Click **Edit...**
- Click **Verify**

Troubleshooting 'ERR_ADD_PRIVILEGED_SHARE_NOT_FOUND'

If the FPolicy Server reports privileged share not found, there is a misconfiguration or SMB issue. Please attempt the following steps:

- Check all configuration using troubleshooting steps described above

5.4. NETAPP FILER

- Ensure the FPolicy Server has no other SMB sessions to Vservers
 - run `net use` from Windows Command Prompt
 - remove all mapped drives
- Reboot the server
- Retry the failed operation
 - Check for new errors in `agent.log`

5.5 Dell EMC Isilon NAS

5.5.1 Link-Migration Support

Dell EMC Isilon does not provide an interface for performing Moonwalk stub-based migration. As an alternative, Moonwalk provides a link-based migration mechanism via a LinkConnect Server. See §4.9 (p.25) for details of the Link-Migrate operation.

Link-Migration works by pairing an Isilon SMB share with a corresponding LinkConnect Cache Share. Typically a top-level share on each Isilon is mapped to a unique share (or subdivision) on a LinkConnect Server. Multiple Isilons may use shares/subdivisions on the same LinkConnect Server if desired.

Once this configuration is completed, Link-Migrate policies convert files on the source Isilon share to links pointing to the destination files via the LinkConnect Cache Share, according to configured rules.

Link-Migrated files can be identified by the 'O' (Offline) attribute in Explorer. Depending on the version of Windows, files with this flag may be displayed with an overlay icon.

Note: If the Link-Migrate operation will not be used, a LinkConnect Server is not necessary. In this case, refer to §5.22.

5.5.2 Planning

Prerequisites

- An NTFS Cache Volume of at least 1TB – see §2.4 (p.11)
- A Moonwalk license that includes an entitlement for LinkConnect Server.
- A supported secondary storage destination (any Moonwalk destination except for Swarm or CloudScaler)

When creating a production deployment plan, please refer to §3.5 (p.18).

NAS System Requirements

- Moonwalk LinkConnect Server requires Isilon OneFS version 8.1.2.0 or higher

Client Requirements

Windows clients require a supported 64-bit Windows operating system:

- Windows 10
- Windows Server 2019
- Windows Server 2016
- Windows Server 2012 R2

In order to access link-migrated files, the LinkConnect Client Driver must be installed on each client machine – see §2.5 (p.12).

Network

Place the Moonwalk LinkConnect Server on the same subnet and same switch as the corresponding Isilon to minimize latency.

Additionally, the LinkConnect Server **must** be joined to the same domain as the Isilon NAS and the Windows client machines.

Antivirus Considerations

Ensure that Windows Defender or any other antivirus product installed on the LinkConnect Server is configured to **omit** scanning/screening on the LinkConnect Cache Volume **and** any Isilon SMB shares.

High-Availability for LinkConnect Server

Consider whether High-Availability (HA) is required in your environment (either now *or in the future*). If so, LinkConnect Servers must be installed in a DFSN configuration from the outset.

LinkConnect Cache Shares are configured for HA by exposing the share name at the domain level using DFSN. If not using HA, it is possible to use either a simple share on a standalone server, or a share exposed at the domain level using DFSN. The latter is always recommended to allow transition to an HA configuration in the future.

Regular Maintenance Activity

Each configured MigLink source will be periodically scanned to perform maintenance tasks such as MigLink ACL propagation and Link Deletion Monitoring (see below).

In an HA configuration, this scanning activity will be performed by a single caretaker node. The current caretaker can be seen on the AdminCenter Servers page. When not configured for HA, a LinkConnect Server always performs the caretaker role.

Link Deletion Monitoring

Similarly to the Stub Deletion Monitoring feature provided by Moonwalk Agents on Windows, Link Deletion Monitoring (LDM) identifies secondary storage files that are no longer referenced in order to facilitate recovery of storage space by Scrub Policies. This feature extends not only to MigLinks that are demigrated or directly deleted by the user, but also to other cases such as overwriting a MigLink or renaming a different file over the top of a MigLink.

Unlike SDM, LDM requires a number of maintenance scans to determine that a given secondary storage file is no longer referenced. It should be noted that interrupting the maintenance process (e.g. by restarting the caretaker node or transitioning the caretaker role) will delay the detection of unreferenced secondary storage. For optimal and timely storage space recovery, ensure that LinkConnect Servers can run uninterrupted for extended periods.

5.5. DELL EMC ISILON NAS

Warning: in order to avoid LDM incorrectly identifying files as deleted – leading to unwanted data loss during Scrub – it is critical to ensure that users cannot *move/rename* MigLinks out of the scanned portion of the directory tree within the filesystem. This can be achieved by always creating the share used for your ‘*miglinkSource*’ at the root of the filesystem. An additional share may be created solely for this purpose.

To utilize LDM, it must first be enabled on a per-share basis.

5.5.3 Setup

Create a LinkConnect User

Provision a user on the Windows domain for the exclusive use of your LinkConnect service(s). This user does *not* need to be a member of Domain Admins.

Configure Isilon

Using the Isilon OneFS Storage Administration web console:

1. Navigate to Access → Membership & Roles → Roles
2. Edit the BackupAdmin role
 - add the LinkConnect user to this role
3. Navigate to Protocols → Windows Sharing (SMB) → SMB Shares
4. Edit the share to be paired with a LinkConnect Cache Share
 - Add the LinkConnect user as a new member
 - Specify ‘*Run as root*’ permission
 - Move the new member to the top of the members list

Installation

On each LinkConnect Server machine:

1. Ensure that the user created above has the ‘Log on as a service’ privilege
2. Run the `Moonwalk LinkConnect Server.exe`
3. Follow the prompts to complete the installation
4. Follow the instructions to activate the installation as a standalone server
 - the Servers page will report that the server is unconfigured

Cache Share Creation

On your cache volume (e.g. X:\), navigate to
`X:\1bf8ce99-8c8a-4092-9c98-2b9c850c57a1\shares.`

To create each Cache Share:

- Create a new folder with the desired share name
- Right click → Properties → Sharing → Advanced Sharing...
- Tick ‘*Share this folder*’

5.5. DELL EMC ISILON NAS

- Share name **must** match the folder name exactly (including case)
- Permissions:
 - Everyone: Allow 'Read' only
 - No other permissions

Service Configuration

On the AdminCenter 'Servers' page, edit the configuration of the LinkConnect Server. In the 'Advanced Options' box, add the following options:

```
linkconnect.config.linkConnectAlias=ALIAS_FQDN
```

where ALIAS_FQDN is either the FQDN of the LinkConnect Server (standalone mode), or of the DFSN domain (standalone or high-availability).

For each share mapping, add:

```
linkconnect.config.MAPPING_NUMBER.miglinkSourceType=isilon
linkconnect.config.MAPPING_NUMBER.miglinkSource=ISILON_FQDN/ISILON_SHARE
linkconnect.config.MAPPING_NUMBER.linkConnectTarget=CACHE_SHARE\SUBDIV
linkconnect.config.MAPPING_NUMBER.key=SECRET_KEY
linkconnect.config.MAPPING_NUMBER.linkDeletionMonitoring.enabled=<bool>
```

where:

- miglinkSourceType must be set to exactly **isilon**
- MAPPING_NUMBER starts at 1 for the first share mapping in this file – mappings must be numbered consecutively
- ISILON_FQDN/ISILON_SHARE describes the Isilon share to be mapped
- CACHE_SHARE is a LinkConnect Cache Share name (created above)
 - this value is CASE-SENSITIVE
- SUBDIV **must** be the single decimal digit 1
- SECRET_KEY is at least 40 ASCII characters – this key protects against counterfeit link creation
 - recommendation: use a password generator with 64 'All Chars'
- linkDeletionMonitoring.enabled may be set to **true** or **false** to enable/disable Link Deletion Monitoring on this share – **see warning above**

If clients will access the storage via nested sub-shares rather than only the top-level configured MigLink Source share, the known sub-shares should be added as follows:

```
linkconnect.config.MAPPING_NUMBER.knownSubShares=share1,share2
```

This list of sub-shares can be updated later as more subdirectories are shared. Where MigLink access occurs on unexpected shares, warnings will be written to the LinkConnect agent.log.

Save the configuration and restart the Moonwalk Agent service.

Important: Refer to §3.3.2 (p.15) to ensure that the configuration on this LinkConnect Server is included in your backup. If the LinkConnect Server needs to be rebuilt, the secret key will be required to enable previously link-migrated files to be securely accessed.

DFSN Configuration

If DFSN is to be used (even if not yet using HA), namespaces and folders must be configured as follows:

1. Add a DFSN namespace:
 - the namespace **must not** be hosted on a LinkConnect Server machine
 - the namespace *name* **must** match the LinkConnect Cache Share name exactly (including case)
 - the namespace **must** be *'Domain-based'*
2. Add a folder to the namespace:
 - folder name must be of the form: SUBDIV_MwC1C_1 e.g. 1_MwC1C_1
 - Add folder target:
 - `\\SERVER\CACHE_SHARE\SUBDIV_MwC1C_1`
 - where SERVER is a LinkConnect Server which exports CACHE_SHARE
 - where CACHE_SHARE matches the namespace name exactly (including case)
 - where SUBDIV_MwC1C_1 matches the new folder name exactly (including case)
 - the folder target will already exist – it was created by the LinkConnect Server in the previous section
 - **DO NOT** enable replication
 - Add additional targets to the same folder for each other LinkConnect Server in the HA group

For example, `\\example.com\CacheA\1_MwC1C_1` may refer to both of the following locations:

```
\\server1.example.com\CacheA\1_MwC1C_1
\\server2.example.com\CacheA\1_MwC1C_1 (optional 2nd server)
```

Recovery of Lost Secret Key

In cases where the keys have been lost and a Moonwalk LinkConnect Server needs to be rebuilt, it is possible to temporarily disable the Counterfeit Link Protection (CLP) and re-sign all links with a new key. To enable this behavior, recreate the configuration as above (with a new secret key), and add a line similar to the following:

```
linkconnect.config.disableSignatureSecurityUntil=2020-04-14T01:00:00Z
```

Regular scanning of the configured share mapping will update the links present in all scanned links to use the new key, and any user-generated access to these links will function without verifying the signatures **until the configured cutoff time**, specified as Zulu Time (GMT). For a large system, it may be necessary to allow several days before the cutoff, to enable key update to complete. Users may continue to access the system during this period.

5.5.4 Usage

URI format

```
smb://{server}/{nas}/{share}/{[path]}
```

5.5. DELL EMC ISILON NAS

Where:

- `server` – FQDN of a LinkConnect Server that is configured to support the Isilon share
- `nas` – Isilon FQDN
- `share` – Isilon SMB share
- `path` – path within the share

Example:

```
smb://link.example.com/isilon.example.com/pub/projects
```

5.5.5 Known Issues

Service Restart Delay

Depending on the cache size, dataset and workload characteristics, the Moonwalk Agent service on the LinkConnect Server may take some time to perform cache cleanup during service restart. During this time, the Moonwalk AdminCenter will not be able to connect to retrieve status information.

5.6 Caringo Swarm

5.6.1 Introduction

The `swarm` scheme should only be used when accessing Swarm storage nodes directly.

The Caringo Swarm product was previously named CASTor. Existing destinations and stubs may continue to use the `castor` scheme with the Swarm Plugin (see also §5.6.5).

If accessing Swarm storage via a CloudScaler Gateway, the `cloudscaler` scheme must be used instead, see §5.7.

Note: Moonwalk software does **not** support access to storage nodes via an SCSP Proxy.

5.6.2 Planning

Before proceeding with the installation, the following will be required:

- Swarm 7.1.1 or above (or CASTor 6.0 or above)
- a license that includes an entitlement for Swarm

Firewall

The Swarm storage node port (TCP port 80 by default) must be allowed by any firewalls between the Moonwalk Swarm Plugin on the Moonwalk Gateway Agent and the Swarm storage nodes. For further information regarding firewall configuration see Appendix B.

Domains and Endpoints

Swarm storage locations are accessed via a configured endpoint FQDN. Add several Swarm storage node IP addresses to DNS under a single endpoint FQDN (4-8 addresses are recommended). If domains are NOT in use (i.e. data will be stored in the default cluster domain), it is **strongly** recommended that the FQDN be the name of the cluster for best Swarm performance.

Where Swarm domains are NOT resolvable in DNS to Swarm cluster nodes, a domain may be specified using the `domain@endpointFQDN` syntax shown in §5.6.5.

Note: In a legacy installation where domains were not previously used, DO NOT create a Swarm domain which matches the FQDN used in existing (or previous) Moonwalk destinations. Such a domain may prevent proper access to the untenanted data already stored in the default cluster domain.

Buckets

Migrated files may be stored as either unnamed objects (accessed by UUID), or as named objects residing in a bucket. Bucket creation must be performed ahead of time, prior to configuring Moonwalk.

Swarm Config will be used to create Destination URIs for use in the AdminCenter.

5.6.3 Setup

Installation

To perform a fresh installation:

1. Run the `Moonwalk Agent.exe`, select the Gateway Agent role (see §2.2.2 (p.10)) and select Swarm Plugin on the 'Components' page
2. Follow the prompts to complete the installation

Or, to add the Swarm Plugin to an existing Gateway Agent:

1. Run the installer for the Moonwalk Swarm Plugin:
`Moonwalk Swarm Plugin.exe`
2. Follow the prompts to complete the installation

Installing 'Moonwalk Swarm Config'

- Run the installer for Moonwalk Swarm Config:
`Moonwalk Swarm Config.exe`

5.6.4 Plugin Configuration

Open 'Moonwalk Swarm Config' and complete the following configuration steps.

Create a Moonwalk Encryption Key

If encryption-at-rest is to be used to protect Moonwalk data on the destination, check 'Enable encryption'. An encryption key must be generated before Moonwalk can be used to store encrypted data on a Swarm migration destination. Moonwalk will encrypt all data migrated using the specified encryption key.

During the encryption key creation process, a copy of the information entered will be printed and it will be strongly recommended that a copy of the `swarm.cfg` file is stored in a safe location.

1. Click **Generate...** in the 'Moonwalk Encryption' section
2. Read the User Confirmation notice and click **Yes** to continue
3. Keep the suggested Key ID
4. Enter a passphrase from which to generate a new encryption key, and click **OK**
 - an *Encryption Key Details page* will be printed
5. When prompted, enter the 'Validation Code' from the printed page

Set Metadata Options

Tick 'Include metadata HTTP headers' to store per-file metadata with the destination objects, such as original filename and location, content-type, owner and timestamps – see §5.6.8 for details. Swarm 8 or above is required to use this option. File extension to content-type mappings may be customized by editing the `swarm-mimetypes` file, found in `C:\Program Files\Moonwalk\data\swarm.data\`.

5.6. CARINGO SWARM

Also tick *'Include Content-Disposition'* to include original filename for use when downloading the target objects directly using a web browser.

Create an Index

Swarm Destinations require an index to be created prior to use.

In Swarm Config:

1. Click **Create Index...**
2. Follow the instructions
3. Use the resultant URI to create a Destination in the AdminCenter

Additional indexes can be added at a later date to further subdivide storage if required.

Important: If multiple Moonwalk deployments are in use migrating to the same Swarm cluster, different Swarm indexes are required for EACH AdminCenter.

Apply Configuration to Gateway Agents

1. Click **Save** to save all changes. Changes will be saved to `swarm.cfg`
2. Copy `swarm.cfg` to the correct location on all Gateway Agent machines:
 - `C:\Program Files\Moonwalk\data\Agent\swarm.cfg`
3. Restart the Moonwalk Agent service on each machine

5.6.5 Usage

URI Format

Note: The following is informational only, Swarm Config should always be used to prepare Swarm URIs.

```
swarm://{gateway}/[domain]@{endpoint}[:port]/?idx={index}
```

```
swarm://{gateway}/[domain]@{endpoint}[:port]/{bucket}[:partition]
```

Where:

- `gateway` – DNS alias for all Moonwalk Swarm Gateways
- `domain` – Swarm Domain name, required if different to endpoint
- `endpoint` – FQDN of the Swarm endpoint
- `port` – override the standard HTTP/HTTPS port
- `index` – index UUID, as created by *Swarm Config*
- `bucket` – bucket in which to store named objects
- `partition` – partition within bucket

Examples:

```
swarm://gw.example.com/data.example.com/?idx=968...
```

```
swarm://gw.example.com/data.example.com/myBucket
```

```
swarm://gw.example.com/data.example.com@cs.example.com/?idx=968...
```

Legacy URIs

URIs created on previous versions of Moonwalk using the `castor` scheme will continue to function as expected. Existing destinations should NOT be updated to use the `swarm` scheme. The `castor` scheme is simply an alias for the `swarm` scheme.

5.6.6 Disaster Recovery Considerations

During migration, each newly migrated file is recorded in the corresponding index. The index may be used in disaster scenarios where:

1. stubs have been lost, and
2. a *Create Recovery File from Source* file is not available, and
3. no current backup of the stubs exists

Index performance is optimized for migrations and demigrations, not for *Create Recovery File from Destination* policies.

Create Recovery File from Source policies are the recommended means to obtain a Recovery file for restoring stubs. This method provides better performance and the most up-to-date stub location information.

It is recommended to regularly run *Create Recovery File from Source* policies following *Migration* policies.

5.6.7 Policy Restrictions

Caringo Swarm may *not* be used as the 'New Destination' for Change Destination Tier or Retarget Destination Policies.

5.6.8 Swarm Metadata Headers

The following metadata fields are supported:

- `X-Alt-Meta-Name` – the original source file's filename (excluding directory path)
- `X-Alt-Meta-Path` – the original source file's directory path (excluding the filename) in a platform-independent manner such that `'/'` is used as the path separator and the path will start with `'/'`, followed by drive/volume/share if appropriate, but not end with `'/'` (unless this path represents the root directory)
- `X-Moonwalk-Meta-Partition` – the Destination URI *partition* – if no partition is present, this header is omitted
- `X-Source-Meta-Host` – the FQDN of the original source file's server
- `X-Source-Meta-Owner` – the owner of the original source file in a format appropriate to the source system (e.g. `DOMAIN\username`)
- `X-Source-Meta-Modified` – the *Last Modified* timestamp of the original source file at the time of migration in RFC3339 format
- `X-Source-Meta-Created` – the *Created* timestamp of the original source file in RFC3339 format

5.6. CARINGO SWARM

- `X-Source-Meta-Attribs` – a case-sensitive sequence of characters {AHRs} representing the original source file's file flags: *Archive*, *Hidden*, *Read-Only* and *System*
 - all other characters are reserved for future use and should be ignored
- `Content-Type` – the MIME Type of the content, determined based on the file-extension of the original source filename

Note: Timestamps may be omitted if the source file timestamps are not set.

Non-ASCII characters will be stored using RFC2047 encoding, as described in the Swarm documentation. Swarm will decode these values prior to indexing in Elasticsearch.

5.7 Caringo CloudScaler

5.7.1 Introduction

Caringo CloudScaler provides a multi-tenanted object storage platform built upon Swarm storage nodes. The Moonwalk `cloudscaler` scheme must only be used when accessing the storage via CloudScaler. To store data on Swarm nodes directly, the `swarm` scheme must be used instead, see §5.6.

5.7.2 Planning

Before proceeding with the installation, the following will be required:

- Cloud Gateway 3.0.0 or above
- Swarm 7.1.1 or above
- a license that includes an entitlement for CloudScaler

Firewall

The TCP port used to access the CloudScaler Gateway via HTTP or HTTPS (possibly by way of a load-balancer) must be allowed by any firewalls between the CloudScaler Plugin on the Gateway Agent and the CloudScaler Gateway endpoints. For further information regarding firewall configuration see Appendix B.

Domains and Buckets

Where CloudScaler domain names are NOT resolvable in DNS to the address of the CloudScaler endpoint, a domain may be specified using the `domain@endpointFQDN` syntax shown in §5.7.5. This is useful when using an HTTPS endpoint where the certificate does not match the storage domain. An alternative is to use a certificate that matches all of your domains using a wildcard.

Migrated files may be stored as either unnamed objects (accessed by UUID), or as named objects residing in a bucket. Bucket creation must be performed ahead of time, prior to configuring Moonwalk.

CloudScaler Config will assist in the creation of a Destination URI for use in the Admin-Center.

Certificate

In order to utilize an HTTPS endpoint, the endpoint's *Root* CA certificate must be trusted by the relevant Gateway Agent. In most cases the Root CA will already be trusted as a pre-installed public root or enterprise-deployed CA. Where this is not the case, install the *Root* CA (or self-signed certificate) in each Gateway's Local Computer *Trusted Root Certification Authorities* store.

5.7.3 Setup

Installation

To perform a fresh installation:

1. Run the `Moonwalk Agent.exe`, select the Gateway Agent role (see §2.2.2 (p.10)) and select CloudScaler Plugin on the 'Components' page
2. Follow the prompts to complete the installation

Or, to add the CloudScaler Plugin to an existing Gateway Agent:

1. Run the installer for the Moonwalk CloudScaler Plugin:
`Moonwalk CloudScaler Plugin.exe`
2. Follow the prompts to complete the installation

Installing 'Moonwalk CloudScaler Config'

- Run the installer for Moonwalk CloudScaler Config:
`Moonwalk CloudScaler Config.exe`

5.7.4 Plugin Configuration

In 'Moonwalk CloudScaler Config':

1. Check 'Use TLS' if the CloudScaler endpoint will be accessed via HTTPS
2. Optionally, fill in the 'HTTP Proxy' section:
 - (a) Check **Use Proxy** if a proxy is required to access the endpoint
 - Avoid using a proxy for best performance
 - This feature is only supported for HTTPS endpoints
 - (b) Enter 'Host' and 'Port'
3. Click **Add...** to add a new set of CloudScaler domain credentials
 - If using named objects, supply the bucket name
 - The bucket must already exist and be configured
4. Specify the CloudScaler storage domain, username and password
 - The domain must already exist and be configured

Create an Index

CloudScaler Destinations require an index to be created prior to use.

In CloudScaler Config:

1. Select the domain in which to create the index
2. Click **Create Index...**
3. Follow the instructions
4. Use the resultant URI to create a Destination in the AdminCenter

Additional indexes can be added at a later date to further subdivide storage if required.

Important: If multiple Moonwalk deployments are in use migrating to the same Swarm cluster, different CloudScaler indexes are required for EACH AdminCenter.

Create a Moonwalk Encryption Key

If encryption-at-rest is to be used to protect Moonwalk data on the destination, check *'Enable encryption'*. An encryption key must be generated before Moonwalk can be used to store encrypted data on a CloudScaler migration destination. Moonwalk will encrypt all data migrated using the specified encryption key.

During the encryption key creation process, a copy of the information entered will be printed and it will be strongly recommended that a copy of the `cloudscaler.cfg` file is stored in a safe location.

1. Click **Generate...** in the *'Moonwalk Encryption'* section
2. Read the User Confirmation notice and click **Yes** to continue
3. Keep the suggested Key ID
4. Enter a passphrase from which to generate a new encryption key, and click **OK**
 - *an Encryption Key Details page will be printed*
5. When prompted, enter the *'Validation Code'* from the printed page

Set Metadata Options

Tick *'Include metadata HTTP headers'* to store per-file metadata with the destination objects, such as original filename and location, content-type, owner and timestamps – see §5.7.8 for details. Swarm 8 or above is required to use this option. File extension to content-type mappings may be customized by editing the `cloudscaler-mimetypes` file, found in `C:\Program Files\Moonwalk\data\cloudscaler.data\`.

Also tick *'Include Content-Disposition'* to include original filename for use when downloading the target objects directly using a web browser.

Apply Configuration to Gateway Agents

1. Click **Save** to save all changes. Changes will be saved to `cloudscaler.cfg`
2. Copy `cloudscaler.cfg` to the correct location on all Gateway Agent machines:
 - `C:\Program Files\Moonwalk\data\Agent\cloudscaler.cfg`
3. Restart the Moonwalk Agent service on each machine

5.7.5 Usage

URI Format

Note: The following is informational only, CloudScaler Config should always be used to prepare CloudScaler URIs.

```
cloudscaler://{gateway}/[domain]@{endpoint}[:port]/?idx={index}
```

```
cloudscaler://{gateway}/[domain]@{endpoint}[:port]/{bucket}[:partition]
```

Where:

- `gateway` – DNS alias for all Moonwalk CloudScaler Gateways
- `domain` – CloudScaler Domain name, required if different to endpoint
- `endpoint` – FQDN of the CloudScaler endpoint

5.7. CARINGO CLOUDSCALER

- `port` – override the standard HTTP/HTTPS port
- `index` – index UUID, as created by *CloudScaler Config*
- `bucket` – bucket in which to store named objects
- `partition` – partition within bucket

Examples:

```
cloudscaler://gw.example.com/data.example.com/?idx=968...
cloudscaler://gw.example.com/data.example.com/myBucket
cloudscaler://gw.example.com/data.example.com@cs.example.com/?idx=968...
```

5.7.6 Disaster Recovery Considerations

During migration, each newly migrated file is recorded in the corresponding index. The index may be used in disaster scenarios where:

1. stubs have been lost, and
2. a *Create Recovery File from Source* file is not available, and
3. no current backup of the stubs exists

Index performance is optimized for migrations and demigrations, not for *Create Recovery File from Destination* policies.

Create Recovery File from Source policies are the recommended means to obtain a Recovery file for restoring stubs. This method provides better performance and the most up-to-date stub location information.

It is recommended to regularly run *Create Recovery File from Source* policies following *Migration* policies.

5.7.7 Policy Restrictions

Caringo CloudScaler may *not* be used as the 'New Destination' for Change Destination Tier or Retarget Destination Policies.

5.7.8 Swarm Metadata Headers

The following metadata fields are supported:

- `X-Alt-Meta-Name` – the original source file's filename (excluding directory path)
- `X-Alt-Meta-Path` – the original source file's directory path (excluding the filename) in a platform-independent manner such that `'/'` is used as the path separator and the path will start with `'/'`, followed by drive/volume/share if appropriate, but not end with `'/'` (unless this path represents the root directory)
- `X-Moonwalk-Meta-Partition` – the Destination URI *partition* – if no partition is present, this header is omitted
- `X-Source-Meta-Host` – the FQDN of the original source file's server
- `X-Source-Meta-Owner` – the owner of the original source file in a format appropriate to the source system (e.g. DOMAIN\username)
- `X-Source-Meta-Modified` – the *Last Modified* timestamp of the original source file at the time of migration in RFC3339 format

5.7. CARINGO CLOUDSCALER

- `X-Source-Meta-Created` – the *Created* timestamp of the original source file in RFC3339 format
- `X-Source-Meta-Attribs` – a case-sensitive sequence of characters {AHRs} representing the original source file's file flags: *Archive*, *Hidden*, *Read-Only* and *System*
 - all other characters are reserved for future use and should be ignored
- `Content-Type` – the MIME Type of the content, determined based on the file-extension of the original source filename

Note: Timestamps may be omitted if the source file timestamps are not set.

Non-ASCII characters will be stored using RFC2047 encoding, as described in the Swarm documentation. Swarm will decode these values prior to indexing in Elasticsearch.

5.8 Hitachi Content Platform (HCP)

5.8.1 Introduction

The Hitachi Content Platform may be used as a migration destination only for Moonwalk. Moonwalk accesses HCP clusters using Authenticated Namespaces (ANS) via HTTPS.

5.8.2 Planning

Before proceeding with the installation, the following will be required:

- HCP 7.2 or above
- The HCP system must have at least one namespace configured for use with Moonwalk:
 - HTTPS must be enabled
 - Versioning should be disabled
 - If using retention, allow metadata 'Add, delete and replace'
- An HCP local user with at least [Browse, Read, Write, Delete, Purge] permissions for the namespace
- A license that includes an entitlement for HCP

Firewall

The HTTPS port (TCP port 443) must be allowed by any firewalls between the Moonwalk HCP Plugin on the Moonwalk Gateway Agent and the HCP cluster.

Certificate

The HCP webserver's *Root CA* certificate must be trusted by the relevant Gateway Agent. In most cases the *Root CA* will already be trusted as a pre-installed public root or enterprise-deployed CA. Where this is not the case, install the *Root CA* (or self-signed certificate) in each Gateway's Local Computer *Trusted Root Certification Authorities* store.

DR Site Replication

For assistance in planning for DR Site Replication, including replicated clusters and Gateways, please contact Moonwalk Support.

5.8.3 Setup

Installation

To perform a fresh installation:

5.8. HITACHI CONTENT PLATFORM (HCP)

1. Run the `Moonwalk Agent.exe`, select the Gateway Agent role (see §2.2.2 (p.10)) and select HCP Plugin on the 'Components' page
2. Follow the prompts to complete the installation

Or, to add the HCP Plugin to an existing Gateway Agent:

1. Run the installer for the Moonwalk HCP Plugin:
`Moonwalk HCP Plugin.exe`
2. Follow the prompts to complete the installation

Moonwalk HCP Config is also required to configure Moonwalk for HCP access.

- Run the installer for Moonwalk HCP Config:
`Moonwalk HCP Config.exe`

5.8.4 Plugin Configuration

Place the CA certificate for the HCP cluster (as mentioned above: §5.8.2) in `hcp-ca` within the Moonwalk Agent data directory (e.g. `C:\Program Files\Moonwalk\data\Agent\hcp-ca\`).

Configure access parameters for the namespace(s) to be used as Moonwalk Destinations:

1. Run the 'Moonwalk HCP Config' tool
2. If using an HTTPS proxy for access to the HCP cluster, enter its details in the 'HTTP Proxy' section
3. Click **Add...** to supply a new set of Authentication Credentials; a dialog will be displayed to allow configuration of authentication details
4. Enter the Cluster, Tenant and Namespace
e.g. `cluster.example.com`, `tenant`, and `namespace` respectively
5. Enter credentials of an HCP **local** user with [Browse, Read, Write, Delete, Purge] Data Access permissions for the Namespace
6. The DR Cluster section may be left blank – for advanced DR Site Replication configurations, please contact Moonwalk Support
7. Click **Get URI** to copy a URI to the clipboard for use in the AdminCenter Destination
 - in AdminCenter, fill in the *gateway* and *path* as required
8. Repeat from step 3 onwards as needed for multiple namespaces. HCP credentials must be configured for each namespace to be used by Moonwalk
9. Save the changes. This will create an `hcp.cfg` file
10. Copy the `hcp.cfg` file to **each** Moonwalk Gateway Agent as directed
 - `C:\Program Files\Moonwalk\data\Agent\hcp.cfg`
11. Restart the Moonwalk Agent service on **each** Gateway Agent

5.8.5 Usage

Namespace FQDNs

HCP namespaces are identified by an FQDN of the form:
`namespace.tenant.cluster.example.com`

5.8. HITACHI CONTENT PLATFORM (HCP)

URI Format

Note: The following is informational only, HCP Config should always be used to prepare HCP URIs.

`hcp://{gateway}/{namespace FQDN}/{path}`

Where the URI components are defined as follows:

- `gateway` – the Moonwalk HCP Gateway FQDN
- `namespace FQDN` – the full namespace FQDN as above
- `path` – starting path within the namespace

Example URI:

`hcp://gw.example.com/ns1.acme.hcpclust.example.com/Archive`

Where:

- gateway machine FQDN – gw.example.com
- HCP namespace – ns1
- HCP tenant – acme
- HCP cluster FQDN – hcpclust.example.com

5.8.6 Behavioral Notes

Retention and Scrub

When running Moonwalk Scrub Policies, files currently under retention will be automatically skipped.

5.9 Amazon S3

5.9.1 Introduction

Amazon S3 may be used as either a migration or ingest destination.

Additionally, Amazon S3 may be used as a source for copy, move and ingest policies. Note that when copying a dataset that did not originate on a filesystem check that the object naming convention will map suitably to the destination filesystem.

This section strictly pertains to *Amazon* S3. Other supported S3-compatible storage services/devices are documented in separate sections.

5.9.2 Planning

Before proceeding with the installation, the following will be required:

- an Amazon Web Services (AWS) Account
- a license that includes an entitlement for Amazon S3

Dedicated buckets should be used for Moonwalk migration data. However, do not create any S3 buckets at this stage – this will be done later using Moonwalk S3 Config.

Firewall

The HTTPS port (TCP port 443) must be allowed by any firewalls between the S3 Plugin on the Moonwalk Gateway Agent and the Internet.

5.9.3 Storage Options

Moonwalk may be configured to use the following S3 features on a per-bucket basis.

Transfer Acceleration

Transfer acceleration allows data to be uploaded via the fastest data center for your location, regardless of the actual location of the bucket.

This option provides a way to upload data to a bucket in a remote AWS region while minimizing the adverse effects on migration policies that would otherwise be caused by the correspondingly higher latency of using the remote region.

Additional AWS charges may apply for using transfer acceleration at upload time, but for archived data these initial charges may be significantly outweighed by reduced storage costs in the target region. For further details, please consult AWS pricing.

Infrequent Access Storage Class

This option allows eligible files to be uploaded *directly* into Infrequent Access Storage (STANDARD_IA) instead of the Standard storage class. This can dramatically reduce costs for infrequently accessed data.

Please consult AWS pricing for further details.

5.9.4 Setup

Installation

To perform a fresh installation:

1. Run the `Moonwalk Agent.exe`, select the Gateway Agent role (see §2.2.2 (p.10)) and select S3 Plugin on the 'Components' page
2. Follow the prompts to complete the installation

Or, to add the S3 Plugin to an existing Gateway Agent:

1. Run the installer for the Moonwalk S3 Plugin:
`Moonwalk S3 Plugin.exe`
2. Follow the prompts to complete the installation

Installing 'Moonwalk S3 Config'

- Run the installer for Moonwalk S3 Config:
`Moonwalk S3 Config.exe`

5.9.5 Plugin Configuration

In the 'Moonwalk S3 Config' tool:

1. Select 'Amazon AWS S3'
2. If required, fill in the 'HTTPS Proxy' section (not recommended for performance reasons)
3. Enter your Amazon Web Services (AWS) account details
4. Select authentication 'Signature Type'
 - AWS4-HMAC-256 is required for newer Amazon data centers
 - AWS2 may be faster – it is safe to try this first
5. Click **Manage Buckets...**
6. Click **New** to create a new bucket
7. Click **Options** to set storage options for the selected bucket (see §5.9.3)
8. To copy a URI to the clipboard for use in the AdminCenter Destination object:
 - Either click **Get Migration URI** to select a partition for migration use
 - OR click **Get Ingest URI** for ingest
9. Optionally, check 'Allow Reduced Redundancy (via s3rr:// URIs)'

Configure Encryption-at-Rest

All Moonwalk S3 traffic is encrypted *in transit* with TLS.

If encryption-at-rest is to be used to protect **migrated** data on the destination, check *'Enable encryption'*. An encryption key must be generated before Moonwalk can be used to store encrypted data on an S3 migration destination. Moonwalk will encrypt all data migrated using the specified encryption key.

During the encryption key creation process, a copy of the information entered will be printed and it will be strongly recommended that a copy of the `s3.cfg` file is stored in a safe location.

1. Click **Generate...** in the *'Moonwalk Encryption Key'* section
2. Read the User Confirmation notice and click **Yes** to continue
3. Keep the suggested Key ID
4. Enter a passphrase from which to generate a new encryption key, and click **OK**
 - *an Encryption Key Details page will be printed*
5. When prompted, enter the *'Validation Code'* from the printed page

Note: Ingested data is not encrypted at-rest.

Apply Configuration to Gateways

1. Click **Save** to save all changes. Changes will be saved to `s3.cfg`
2. Ensure the `s3.cfg` file has been copied to the correct location on all Gateway machines:
 - `C:\Program Files\Moonwalk\data\Agent\s3.cfg`
3. Restart the Moonwalk Agent service on each Gateway machine

5.9.6 Usage

URI Format

For migration destinations – `s3://{gateway}/{bucket}[:{partition}]`

For other uses – `s3://{gateway}/{bucket}[/]{path...}`

Where:

- `gateway` – DNS alias for all Moonwalk S3 Gateways
- `bucket` – name of the S3 destination bucket
- `partition` – an optional partition within the S3 bucket
- `path` – an optional path prefix

If the partition does not already exist, it will be created when files are migrated. If a partition is not specified in the URI, the default partition will be used. It is not necessary to use multiple buckets to subdivide storage. Partitions are useful because *'Create Recovery File from Destination'* Policies are performed on partitions rather than whole buckets.

5.9.7 Ingest Metadata Fields

If enabled in an Ingest Policy, metadata is stored as described below. For more information about the Ingest operation, see §4.12 (p.26).

Header Field	Content
x-amz-meta-orig-host	Source server FQDN
x-amz-meta-orig-name	Original filename (without path)
x-amz-meta-orig-modified-time	Modified timestamp
x-amz-meta-orig-created-time	Creation timestamp
x-amz-meta-orig-attrs	Subset of characters {AHR\$} representing the original source file's flags
Content-Disposition (optional)	Original name for web browser download
Security Details <i>as appropriate</i>	
x-amz-meta-orig-owner	File owner – e.g. Domain\JoeUser
x-amz-meta-orig-sddl	Microsoft SDDL format security descriptor
x-amz-meta-orig-uid	Unix user ID
x-amz-meta-orig-gid	Unix group ID
x-amz-meta-orig-unix-perms	Octal permissions e.g. 00644
x-amz-meta-orig-nss-acl	OES Linux NSS IRM and trustee grants

Notes:

- headers will be sent in UTF-8 using RFC2047 encoding as necessary to unambiguously represent the original metadata values (in accordance with the HTTP/1.1 specification – see RFC2616/2.2)
- due to Amazon-specific limitations, sequences of adjacent whitespace within x-amz-meta-orig-name may be returned as a single space by some client software
- all timestamps are stored as UTC in RFC3339 format

Custom Metadata

In addition to the fields above, Ingest policies can optionally specify an additional metadata field to be attached to each upload in <Header>: value format.

Permitted fields include: x-amz-meta-<field> (that is, user metadata), x-amz-grant-<permission>, x-amz-acl, x-amz-tagging and x-amz-storage-class. It is the user's responsibility to ensure that these headers are used in a way that is consistent with the storage service's documentation.

5.9.8 Reduced Redundancy Storage

Reduced Redundancy Storage (RRS) is a slightly lower cost Amazon S3 storage option (when compared to the S3 *Standard* storage class) where data is replicated fewer times. Care should be taken when assessing whether the lower durability of RRS is appropriate.

Reduced Redundancy must be enabled via Moonwalk S3 Config, see §5.9.5.

Reduced Redundancy URI Format

The `s3rr://` scheme is not listed in the AdminCenter Destination Editor and must be entered manually. The URI format follows the same pattern as regular s3 URIs.

5.10 Aquari Storage

5.10.1 Introduction

Aquari Storage may be used as either a migration or ingest destination and is accessed via the S3 protocol.

5.10.2 Planning

Before proceeding with the installation, the following will be required:

- suitable S3 API credentials
- a license that includes an entitlement for Aquari Storage

Dedicated buckets should be used for Moonwalk migration data. However, do not create any S3 buckets at this stage – this will be done later using Moonwalk S3 Config.

Firewall

The S3 port must be allowed by any firewalls between the S3 Plugin on the Moonwalk Gateway Agent and the storage endpoint.

5.10.3 Setup

Installation

To perform a fresh installation:

1. Run the `Moonwalk Agent.exe`, select the Gateway Agent role (see §2.2.2 (p.10)) and select S3 Plugin on the 'Components' page
2. Follow the prompts to complete the installation

Or, to add the S3 Plugin to an existing Gateway Agent:

1. Run the installer for the Moonwalk S3 Plugin:
`Moonwalk S3 Plugin.exe`
2. Follow the prompts to complete the installation

Installing 'Moonwalk S3 Config'

- Run the installer for Moonwalk S3 Config:
`Moonwalk S3 Config.exe`

5.10.4 Plugin Configuration

In the *'Moonwalk S3 Config'* tool:

1. Select *'Aquari Storage'*
2. Enter the S3 target server details
3. If required, fill in the *'HTTPS Proxy'* section (not recommended for performance reasons)
4. Enter your S3 account details
5. Click **Manage Buckets...**
6. Click **New** to create a new bucket
7. To copy a URI to the clipboard for use in the AdminCenter Destination object:
 - Either click **Get Migration URI** to select a partition for migration use
 - OR click **Get Ingest URI** for ingest

Configure Encryption-at-Rest

If HTTPS is enabled, all Moonwalk S3 traffic is encrypted *in transit* with TLS.

If encryption-at-rest is to be used to protect **migrated** data on the destination, check *'Enable encryption'*. An encryption key must be generated before Moonwalk can be used to store encrypted data on an S3 migration destination. Moonwalk will encrypt all data migrated using the specified encryption key.

During the encryption key creation process, a copy of the information entered will be printed and it will be strongly recommended that a copy of the `s3aquari.cfg` file is stored in a safe location.

1. Click **Generate...** in the *'Moonwalk Encryption Key'* section
2. Read the User Confirmation notice and click **Yes** to continue
3. Keep the suggested Key ID
4. Enter a passphrase from which to generate a new encryption key, and click **OK**
 - *an Encryption Key Details page will be printed*
5. When prompted, enter the *'Validation Code'* from the printed page

Note: Ingested data is not encrypted at-rest.

Apply Configuration to Gateways

1. Click **Save** to save all changes. Changes will be saved to `s3aquari.cfg`
2. Ensure the `s3aquari.cfg` file has been copied to the correct location on all Gateway machines:
 - `C:\Program Files\Moonwalk\data\Agent\s3aquari.cfg`
3. Restart the Moonwalk Agent service on each Gateway machine

5.10.5 Usage

URI Format

Note: The following is informational only, S3 Config should always be used to prepare S3 URIs.

5.10. AQUARI STORAGE

For migration – `s3aquari://{gateway}/{endpoint}/{bucket}[:{partition}]`

For ingest – `s3aquari://{gateway}/{endpoint}/{bucket}[/{path...}]`

Where:

- `gateway` – DNS alias for all Moonwalk S3 Gateways
- `endpoint` – S3 target server FQDN
- `bucket` – name of the S3 destination bucket
- `partition` – an optional partition within the S3 bucket
- `path` – an optional path prefix

If the partition does not already exist, it will be created when files are migrated. If a partition is not specified in the URI, the default partition will be used. It is not necessary to use multiple buckets to subdivide storage. Partitions are useful because ‘*Create Recovery File from Destination*’ Policies are performed on partitions rather than whole buckets.

5.10.6 Ingest Metadata Fields

Please refer to §5.9.7 for S3 ingest metadata field details.

5.11 Clouidian HyperStore

5.11.1 Introduction

Clouidian HyperStore may be used as either a migration or ingest destination and is accessed via the S3 protocol.

5.11.2 Planning

Before proceeding with the installation, the following will be required:

- suitable S3 API credentials
- a license that includes an entitlement for Clouidian HyperStore

Dedicated buckets should be used for Moonwalk migration data. However, do not create any S3 buckets at this stage – this will be done later using Moonwalk S3 Config.

Firewall

The S3 port must be allowed by any firewalls between the S3 Plugin on the Moonwalk Gateway Agent and the storage endpoint.

Certificate

In order to utilize an HTTPS endpoint, the endpoint's *Root* CA certificate must be trusted by the relevant Gateway Agent. In most cases the Root CA will already be trusted as a pre-installed public root or enterprise-deployed CA. Where this is not the case, install the *Root* CA (or self-signed certificate) in each Gateway's Local Computer *Trusted Root Certification Authorities* store.

5.11.3 Setup

Installation

To perform a fresh installation:

1. Run the `Moonwalk Agent.exe`, select the Gateway Agent role (see §2.2.2 (p.10)) and select S3 Plugin on the 'Components' page
2. Follow the prompts to complete the installation

Or, to add the S3 Plugin to an existing Gateway Agent:

1. Run the installer for the Moonwalk S3 Plugin:
`Moonwalk S3 Plugin.exe`
2. Follow the prompts to complete the installation

Installing 'Moonwalk S3 Config'

- Run the installer for Moonwalk S3 Config:
Moonwalk S3 Config.exe

5.11.4 Plugin Configuration

In the 'Moonwalk S3 Config' tool:

1. Select 'Cloudian HyperStore'
2. Enter the S3 target server details
3. If required, fill in the 'HTTPS Proxy' section (not recommended for performance reasons)
4. Enter your S3 account details
5. Select authentication 'Signature Type'
 - Note: AWS4-HMAC-256 may require additional HyperStore configuration
6. Click **Manage Buckets...**
7. Click **New** to create a new bucket
8. To copy a URI to the clipboard for use in the AdminCenter Destination object:
 - Either click **Get Migration URI** to select a partition for migration use
 - OR click **Get Ingest URI** for ingest

Configure Encryption-at-Rest

If HTTPS is enabled, all Moonwalk S3 traffic is encrypted *in transit* with TLS.

If encryption-at-rest is to be used to protect **migrated** data on the destination, check 'Enable encryption'. An encryption key must be generated before Moonwalk can be used to store encrypted data on an S3 migration destination. Moonwalk will encrypt all data migrated using the specified encryption key.

During the encryption key creation process, a copy of the information entered will be printed and it will be strongly recommended that a copy of the `s3cloudian.cfg` file is stored in a safe location.

1. Click **Generate...** in the 'Moonwalk Encryption Key' section
2. Read the User Confirmation notice and click **Yes** to continue
3. Keep the suggested Key ID
4. Enter a passphrase from which to generate a new encryption key, and click **OK**
 - *an Encryption Key Details page will be printed*
5. When prompted, enter the 'Validation Code' from the printed page

Note: Ingested data is not encrypted at-rest.

Apply Configuration to Gateways

1. Click **Save** to save all changes. Changes will be saved to `s3cloudian.cfg`
2. Ensure the `s3cloudian.cfg` file has been copied to the correct location on all Gateway machines:
 - `C:\Program Files\Moonwalk\data\Agent\s3cloudian.cfg`
3. Restart the Moonwalk Agent service on each Gateway machine

5.11.5 Compatibility and Limitations

For HyperStore installations that feature an external HTTP proxy load-balancer in front of the storage nodes, ensure that the load-balancer is fully HTTP/1.1 compliant. In particular, Moonwalk requires correct support for HTTP 'Expect: 100-continue' headers.

Moonwalk does not support the following operations for HyperStore destinations:

- Scrub
- Create Recovery File From Destination

Note: The 'Create Recovery File From *Source*' operation is still supported.

5.11.6 Usage

URI Format

Note: The following is informational only, S3 Config should always be used to prepare S3 URIs.

For migration – `s3cloudian://{gateway}/{endpoint}/{bucket}[:{partition}]`

For ingest – `s3cloudian://{gateway}/{endpoint}/{bucket}[/]{path...}`

Where:

- `gateway` – DNS alias for all Moonwalk S3 Gateways
- `endpoint` – S3 target server FQDN
- `bucket` – name of the S3 destination bucket
- `partition` – an optional partition within the S3 bucket
- `path` – an optional path prefix

If the partition does not already exist, it will be created when files are migrated. If a partition is not specified in the URI, the default partition will be used. It is not necessary to use multiple buckets to subdivide storage.

5.11.7 Ingest Metadata Fields

Please refer to §5.9.7 for S3 ingest metadata field details.

5.12 Dell EMC Elastic Cloud Storage

5.12.1 Introduction

Dell EMC Elastic Cloud Storage (ECS) may be used as either a migration or ingest destination and is accessed via the S3 protocol.

5.12.2 Planning

Before proceeding with the installation, the following will be required:

- suitable S3 API credentials
- a license that includes an entitlement for Dell EMC ECS

Dedicated buckets should be used for Moonwalk migration data. However, do not create any S3 buckets at this stage – this will be done later using Moonwalk S3 Config.

Firewall

The S3 port must be allowed by any firewalls between the S3 Plugin on the Moonwalk Gateway Agent and the storage endpoint.

Certificate

The ECS service's *Root CA* certificate must be trusted by the relevant Gateway Agent. In most cases the Root CA will already be trusted as a pre-installed public root or enterprise-deployed CA. Where this is not the case, install the *Root CA* (or self-signed certificate) in each Gateway's Local Computer *Trusted Root Certification Authorities* store.

5.12.3 Setup

Installation

To perform a fresh installation:

1. Run the `Moonwalk Agent.exe`, select the Gateway Agent role (see §2.2.2 (p.10)) and select S3 Plugin on the 'Components' page
2. Follow the prompts to complete the installation

Or, to add the S3 Plugin to an existing Gateway Agent:

1. Run the installer for the Moonwalk S3 Plugin:
`Moonwalk S3 Plugin.exe`
2. Follow the prompts to complete the installation

Installing 'Moonwalk S3 Config'

- Run the installer for Moonwalk S3 Config:
Moonwalk S3 Config.exe

5.12.4 Plugin Configuration

In the 'Moonwalk S3 Config' tool:

1. Select 'Dell EMC ECS'
2. Enter the S3 target server details
3. If required, fill in the 'HTTPS Proxy' section (not recommended for performance reasons)
4. Enter your S3 account details
5. Click **Manage Buckets...**
6. Click **New** to create a new bucket
7. To copy a URI to the clipboard for use in the AdminCenter Destination object:
 - Either click **Get Migration URI** to select a partition for migration use
 - OR click **Get Ingest URI** for ingest

Configure Encryption-at-Rest

All Moonwalk S3 traffic is encrypted *in transit* with TLS.

If encryption-at-rest is to be used to protect **migrated** data on the destination, check 'Enable encryption'. An encryption key must be generated before Moonwalk can be used to store encrypted data on an S3 migration destination. Moonwalk will encrypt all data migrated using the specified encryption key.

During the encryption key creation process, a copy of the information entered will be printed and it will be strongly recommended that a copy of the `s3ecs.cfg` file is stored in a safe location.

1. Click **Generate...** in the 'Moonwalk Encryption Key' section
2. Read the User Confirmation notice and click **Yes** to continue
3. Keep the suggested Key ID
4. Enter a passphrase from which to generate a new encryption key, and click **OK**
 - *an Encryption Key Details page will be printed*
5. When prompted, enter the 'Validation Code' from the printed page

Note: Ingested data is not encrypted at-rest.

Apply Configuration to Gateways

1. Click **Save** to save all changes. Changes will be saved to `s3ecs.cfg`
2. Ensure the `s3ecs.cfg` file has been copied to the correct location on all Gateway machines:
 - `C:\Program Files\Moonwalk\data\Agent\s3ecs.cfg`
3. Restart the Moonwalk Agent service on each Gateway machine

5.12.5 Usage

URI Format

Note: The following is informational only, S3 Config should always be used to prepare S3 URIs.

For migration – `s3ecs://{gateway}/{endpoint}/{bucket}[:{partition}]`

For ingest – `s3ecs://{gateway}/{endpoint}/{bucket}[/]{path...}`

Where:

- `gateway` – DNS alias for all Moonwalk S3 Gateways
- `endpoint` – S3 target server FQDN
- `bucket` – name of the S3 destination bucket
- `partition` – an optional partition within the S3 bucket
- `path` – an optional path prefix

If the partition does not already exist, it will be created when files are migrated. If a partition is not specified in the URI, the default partition will be used. It is not necessary to use multiple buckets to subdivide storage. Partitions are useful because *'Create Recovery File from Destination'* Policies are performed on partitions rather than whole buckets.

5.12.6 Ingest Metadata Fields

Please refer to §5.9.7 for S3 ingest metadata field details.

5.13 IBM Cloud Object Storage

5.13.1 Introduction

IBM Cloud Object Storage (COS) may be used as either a migration or ingest destination and is accessed via the S3 protocol.

Additionally, IBM COS may be used as a source for copy, move and ingest policies. Note that when copying a dataset that did not originate on a filesystem check that the object naming convention will map suitably to the destination filesystem.

5.13.2 Planning

Before proceeding with the installation, the following will be required:

- suitable S3 API credentials
- a license that includes an entitlement for IBM COS

Dedicated buckets should be used for Moonwalk migration data. However, do not create any S3 buckets at this stage – this will be done later using Moonwalk S3 Config.

Firewall

The S3 port must be allowed by any firewalls between the S3 Plugin on the Moonwalk Gateway Agent and the storage endpoint.

Certificate

In order to utilize an HTTPS endpoint, the endpoint's *Root* CA certificate must be trusted by the relevant Gateway Agent. In most cases the Root CA will already be trusted as a pre-installed public root or enterprise-deployed CA. Where this is not the case, install the *Root* CA (or self-signed certificate) in each Gateway's Local Computer *Trusted Root Certification Authorities* store.

5.13.3 Setup

Installation

To perform a fresh installation:

1. Run the `Moonwalk Agent.exe`, select the Gateway Agent role (see §2.2.2 (p.10)) and select S3 Plugin on the 'Components' page
2. Follow the prompts to complete the installation

Or, to add the S3 Plugin to an existing Gateway Agent:

1. Run the installer for the Moonwalk S3 Plugin:
`Moonwalk S3 Plugin.exe`
2. Follow the prompts to complete the installation

Installing 'Moonwalk S3 Config'

- Run the installer for Moonwalk S3 Config:
Moonwalk S3 Config.exe

5.13.4 Plugin Configuration

In the 'Moonwalk S3 Config' tool:

1. Select 'IBM Cloud Object Storage'
2. Enter the S3 target FQDN and port
3. If required, fill in the 'HTTPS Proxy' section (not recommended for performance reasons)
4. Enter your S3 account details
5. Select authentication 'Signature Type'
6. Click **Manage Buckets...**
7. Click **New** to create a new bucket
8. To copy a URI to the clipboard for use in the AdminCenter Destination object:
 - Either click **Get Migration URI** to select a partition for migration use
 - OR click **Get Ingest URI** for ingest

Configure Encryption-at-Rest

If HTTPS is enabled, all Moonwalk S3 traffic is encrypted *in transit* with TLS.

If encryption-at-rest is to be used to protect **migrated** data on the destination, check 'Enable encryption'. An encryption key must be generated before Moonwalk can be used to store encrypted data on an S3 migration destination. Moonwalk will encrypt all data migrated using the specified encryption key.

During the encryption key creation process, a copy of the information entered will be printed and it will be strongly recommended that a copy of the `s3bluemix.cfg` file is stored in a safe location.

1. Click **Generate...** in the 'Moonwalk Encryption Key' section
2. Read the User Confirmation notice and click **Yes** to continue
3. Keep the suggested Key ID
4. Enter a passphrase from which to generate a new encryption key, and click **OK**
 - an Encryption Key Details page will be printed
5. When prompted, enter the 'Validation Code' from the printed page

Note: Ingested data is not encrypted at-rest.

Virtual Host Access

IBM Cloud Object Storage supports the virtual-host-style bucket access method as expected for the S3 protocol. For example `https://bucket.cos.example.com` rather than `https://cos.example.com/bucket`. This facilitates connecting to a node in the correct location for the bucket.

5.13. IBM CLOUD OBJECT STORAGE

Generally the *'Enable Virtual Host Access'* option should be enabled (the default) to ensure optimal performance and correct operation.

Note: when using Virtual Host Access in conjunction with HTTPS (recommended) it is important to ensure that the endpoint's TLS certificate has been created correctly. For example, if the endpoint FQDN is `cos.example.com`, the certificate must contain Subject Alternative Names (SANs) for both `cos.example.com` **and** `*.cos.example.com`.

Apply Configuration to Gateways

1. Click **Save** to save all changes. Changes will be saved to `s3bluemix.cfg`
2. Ensure the `s3bluemix.cfg` file has been copied to the correct location on all Gateway machines:
 - `C:\Program Files\Moonwalk\data\Agent\s3bluemix.cfg`
3. Restart the Moonwalk Agent service on each Gateway machine

5.13.5 Usage

URI Format

For migration – `s3bluemix://{gateway}/{endpoint}/{bucket}[:{partition}]`

For other uses – `s3bluemix://{gateway}/{endpoint}/{bucket}[/]{path...}`

Where:

- `gateway` – DNS alias for all Moonwalk S3 Gateways
- `endpoint` – S3 target server FQDN
- `bucket` – name of the S3 destination bucket
- `partition` – an optional partition within the S3 bucket
- `path` – an optional path prefix

If the partition does not already exist, it will be created when files are migrated. If a partition is not specified in the URI, the default partition will be used. It is not necessary to use multiple buckets to subdivide storage. Partitions are useful because *'Create Recovery File from Destination'* Policies are performed on partitions rather than whole buckets.

5.13.6 Ingest Metadata Fields

Please refer to §5.9.7 for S3 ingest metadata field details.

5.14 IBM Spectrum Scale

5.14.1 Introduction

IBM Spectrum Scale may be used as either a migration or ingest destination and is accessed via the S3 protocol.

5.14.2 Planning

Before proceeding with the installation, the following will be required:

- suitable S3 API credentials
- a license that includes an entitlement for IBM Spectrum Scale

Dedicated buckets should be used for Moonwalk migration data. However, do not create any S3 buckets at this stage – this will be done later using Moonwalk S3 Config.

Firewall

The S3 port must be allowed by any firewalls between the S3 Plugin on the Moonwalk Gateway Agent and the storage endpoint.

Certificate

In order to utilize an HTTPS endpoint, the endpoint's *Root* CA certificate must be trusted by the relevant Gateway Agent. In most cases the Root CA will already be trusted as a pre-installed public root or enterprise-deployed CA. Where this is not the case, install the *Root* CA (or self-signed certificate) in each Gateway's Local Computer *Trusted Root Certification Authorities* store.

5.14.3 Setup

Installation

To perform a fresh installation:

1. Run the `Moonwalk Agent.exe`, select the Gateway Agent role (see §2.2.2 (p.10)) and select S3 Plugin on the 'Components' page
2. Follow the prompts to complete the installation

Or, to add the S3 Plugin to an existing Gateway Agent:

1. Run the installer for the Moonwalk S3 Plugin:
`Moonwalk S3 Plugin.exe`
2. Follow the prompts to complete the installation

Installing 'Moonwalk S3 Config'

- Run the installer for Moonwalk S3 Config:
Moonwalk S3 Config.exe

5.14.4 Plugin Configuration

In the 'Moonwalk S3 Config' tool:

1. Select 'IBM Spectrum Scale'
2. Enter the S3 target server details
3. If required, fill in the 'HTTPS Proxy' section (not recommended for performance reasons)
4. Enter your S3 account details
5. Click **Manage Buckets...**
6. Click **New** to create a new bucket
7. To copy a URI to the clipboard for use in the AdminCenter Destination object:
 - Either click **Get Migration URI** to select a partition for migration use
 - OR click **Get Ingest URI** for ingest

Configure Encryption-at-Rest

If HTTPS is enabled, all Moonwalk S3 traffic is encrypted *in transit* with TLS.

If encryption-at-rest is to be used to protect **migrated** data on the destination, check 'Enable encryption'. An encryption key must be generated before Moonwalk can be used to store encrypted data on an S3 migration destination. Moonwalk will encrypt all data migrated using the specified encryption key.

During the encryption key creation process, a copy of the information entered will be printed and it will be strongly recommended that a copy of the `s3spectrumscale.cfg` file is stored in a safe location.

1. Click **Generate...** in the 'Moonwalk Encryption Key' section
2. Read the User Confirmation notice and click **Yes** to continue
3. Keep the suggested Key ID
4. Enter a passphrase from which to generate a new encryption key, and click **OK**
 - *an Encryption Key Details page will be printed*
5. When prompted, enter the 'Validation Code' from the printed page

Note: Ingested data is not encrypted at-rest.

Apply Configuration to Gateways

1. Click **Save** to save all changes. Changes will be saved to `s3spectrumscale.cfg`
2. Ensure the `s3spectrumscale.cfg` file has been copied to the correct location on all Gateway machines:
 - `C:\Program Files\Moonwalk\data\Agent\s3spectrumscale.cfg`
3. Restart the Moonwalk Agent service on each Gateway machine

5.14.5 Usage

URI Format

Note: The following is informational only, S3 Config should always be used to prepare S3 URIs.

For migration – `s3scale://{gateway}/{endpoint}/{bucket}[:{partition}]`

For ingest – `s3scale://{gateway}/{endpoint}/{bucket}[/]{path...}`

Where:

- `gateway` – DNS alias for all Moonwalk S3 Gateways
- `endpoint` – S3 target server FQDN
- `bucket` – name of the S3 destination bucket
- `partition` – an optional partition within the S3 bucket
- `path` – an optional path prefix

If the partition does not already exist, it will be created when files are migrated. If a partition is not specified in the URI, the default partition will be used. It is not necessary to use multiple buckets to subdivide storage. Partitions are useful because 'Create Recovery File from Destination' Policies are performed on partitions rather than whole buckets.

5.14.6 Ingest Metadata Fields

Please refer to §5.9.7 for S3 ingest metadata field details.

5.15 NetApp StorageGRID

5.15.1 Introduction

NetApp StorageGRID may be used as either a migration or ingest destination and is accessed via the S3 protocol.

5.15.2 Planning

Before proceeding with the installation, the following will be required:

- suitable S3 API credentials
- a license that includes an entitlement for NetApp StorageGRID

Dedicated buckets should be used for Moonwalk migration data. However, do not create any S3 buckets at this stage – this will be done later using Moonwalk S3 Config.

Firewall

The S3 port must be allowed by any firewalls between the S3 Plugin on the Moonwalk Gateway Agent and the storage endpoint.

Certificate

In order to utilize an HTTPS endpoint, the endpoint's *Root* CA certificate must be trusted by the relevant Gateway Agent. In most cases the Root CA will already be trusted as a pre-installed public root or enterprise-deployed CA. Where this is not the case, install the *Root* CA (or self-signed certificate) in each Gateway's Local Computer *Trusted Root Certification Authorities* store.

5.15.3 Setup

Installation

To perform a fresh installation:

1. Run the `Moonwalk Agent.exe`, select the Gateway Agent role (see §2.2.2 (p.10)) and select S3 Plugin on the 'Components' page
2. Follow the prompts to complete the installation

Or, to add the S3 Plugin to an existing Gateway Agent:

1. Run the installer for the Moonwalk S3 Plugin:
`Moonwalk S3 Plugin.exe`
2. Follow the prompts to complete the installation

Installing 'Moonwalk S3 Config'

- Run the installer for Moonwalk S3 Config:
Moonwalk S3 Config.exe

5.15.4 Plugin Configuration

In the 'Moonwalk S3 Config' tool:

1. Select 'NetApp StorageGRID'
2. Enter the S3 target server details
3. If required, fill in the 'HTTPS Proxy' section (not recommended for performance reasons)
4. Enter your S3 account details
5. Select authentication 'Signature Type'
6. Click **Manage Buckets...**
7. Click **New** to create a new bucket
8. To copy a URI to the clipboard for use in the AdminCenter Destination object:
 - Either click **Get Migration URI** to select a partition for migration use
 - OR click **Get Ingest URI** for ingest

Configure Encryption-at-Rest

If HTTPS is enabled, all Moonwalk S3 traffic is encrypted *in transit* with TLS.

If encryption-at-rest is to be used to protect **migrated** data on the destination, check 'Enable encryption'. An encryption key must be generated before Moonwalk can be used to store encrypted data on an S3 migration destination. Moonwalk will encrypt all data migrated using the specified encryption key.

During the encryption key creation process, a copy of the information entered will be printed and it will be strongly recommended that a copy of the `s3nsg.cfg` file is stored in a safe location.

1. Click **Generate...** in the 'Moonwalk Encryption Key' section
2. Read the User Confirmation notice and click **Yes** to continue
3. Keep the suggested Key ID
4. Enter a passphrase from which to generate a new encryption key, and click **OK**
 - *an Encryption Key Details page will be printed*
5. When prompted, enter the 'Validation Code' from the printed page

Note: Ingested data is not encrypted at-rest.

Apply Configuration to Gateways

1. Click **Save** to save all changes. Changes will be saved to `s3nsg.cfg`
2. Ensure the `s3nsg.cfg` file has been copied to the correct location on all Gateway machines:
 - `C:\Program Files\Moonwalk\data\Agent\s3nsg.cfg`
3. Restart the Moonwalk Agent service on each Gateway machine

5.15.5 Usage

URI Format

Note: The following is informational only, S3 Config should always be used to prepare S3 URIs.

For migration – `s3nsg://{gateway}/{endpoint}/{bucket}[:{partition}]`

For ingest – `s3nsg://{gateway}/{endpoint}/{bucket}[/]{path...}`

Where:

- `gateway` – DNS alias for all Moonwalk S3 Gateways
- `endpoint` – S3 target server FQDN
- `bucket` – name of the S3 destination bucket
- `partition` – an optional partition within the S3 bucket
- `path` – an optional path prefix

If the partition does not already exist, it will be created when files are migrated. If a partition is not specified in the URI, the default partition will be used. It is not necessary to use multiple buckets to subdivide storage. Partitions are useful because 'Create Recovery File from Destination' Policies are performed on partitions rather than whole buckets.

5.15.6 Ingest Metadata Fields

Please refer to §5.9.7 for S3 ingest metadata field details.

Note: NetApp Storage Grid has been observed to convert filenames to lowercase in the Content-Disposition field. This is not caused by Moonwalk. The `x-amz-meta-orig-name` field will contain the filename with the correct original case.

5.16 Scality RING

5.16.1 Introduction

Scality RING may be used as either a migration or ingest destination and is accessed via the S3 protocol.

5.16.2 Planning

Before proceeding with the installation, the following will be required:

- suitable S3 API credentials
- a license that includes an entitlement for Scality RING

Dedicated buckets should be used for Moonwalk migration data. However, do not create any S3 buckets at this stage – this will be done later using Moonwalk S3 Config.

Firewall

The S3 port must be allowed by any firewalls between the S3 Plugin on the Moonwalk Gateway Agent and the storage endpoint.

Certificate

The Scality endpoint's *Root* CA certificate must be trusted by the relevant Gateway Agent. In most cases the Root CA will already be trusted as a pre-installed public root or enterprise-deployed CA. Where this is not the case, install the *Root* CA (or self-signed certificate) in each Gateway's Local Computer *Trusted Root Certification Authorities* store.

5.16.3 Setup

Installation

To perform a fresh installation:

1. Run the `Moonwalk Agent.exe`, select the Gateway Agent role (see §2.2.2 (p.10)) and select S3 Plugin on the 'Components' page
2. Follow the prompts to complete the installation

Or, to add the S3 Plugin to an existing Gateway Agent:

1. Run the installer for the Moonwalk S3 Plugin:
`Moonwalk S3 Plugin.exe`
2. Follow the prompts to complete the installation

Installing 'Moonwalk S3 Config'

- Run the installer for Moonwalk S3 Config:
Moonwalk S3 Config.exe

5.16.4 Plugin Configuration

In the 'Moonwalk S3 Config' tool:

1. Select 'Scality'
2. Enter the S3 target server details
3. If required, fill in the 'HTTPS Proxy' section (not recommended for performance reasons)
4. Enter your S3 account details
5. Click **Manage Buckets...**
6. Click **New** to create a new bucket
7. To copy a URI to the clipboard for use in the AdminCenter Destination object:
 - Either click **Get Migration URI** to select a partition for migration use
 - OR click **Get Ingest URI** for ingest

Configure Encryption-at-Rest

All Moonwalk S3 traffic is encrypted *in transit* with TLS.

If encryption-at-rest is to be used to protect **migrated** data on the destination, check 'Enable encryption'. An encryption key must be generated before Moonwalk can be used to store encrypted data on an S3 migration destination. Moonwalk will encrypt all data migrated using the specified encryption key.

During the encryption key creation process, a copy of the information entered will be printed and it will be strongly recommended that a copy of the `s3scality.cfg` file is stored in a safe location.

1. Click **Generate...** in the 'Moonwalk Encryption Key' section
2. Read the User Confirmation notice and click **Yes** to continue
3. Keep the suggested Key ID
4. Enter a passphrase from which to generate a new encryption key, and click **OK**
 - *an Encryption Key Details page will be printed*
5. When prompted, enter the 'Validation Code' from the printed page

Note: Ingested data is not encrypted at-rest.

Apply Configuration to Gateways

1. Click **Save** to save all changes. Changes will be saved to `s3scality.cfg`
2. Ensure the `s3scality.cfg` file has been copied to the correct location on all Gateway machines:
 - `C:\Program Files\Moonwalk\data\Agent\s3scality.cfg`
3. Restart the Moonwalk Agent service on each Gateway machine

5.16.5 Usage

URI Format

Note: The following is informational only, S3 Config should always be used to prepare S3 URIs.

For migration – `s3scality://{gateway}/{endpoint}/{bucket}[:{partition}]`

For ingest – `s3scality://{gateway}/{endpoint}/{bucket}[/{path...}]`

Where:

- `gateway` – DNS alias for all Moonwalk S3 Gateways
- `endpoint` – S3 target server FQDN
- `bucket` – name of the S3 destination bucket
- `partition` – an optional partition within the S3 bucket
- `path` – an optional path prefix

If the partition does not already exist, it will be created when files are migrated. If a partition is not specified in the URI, the default partition will be used. It is not necessary to use multiple buckets to subdivide storage. Partitions are useful because *'Create Recovery File from Destination'* Policies are performed on partitions rather than whole buckets.

5.16.6 Ingest Metadata Fields

Please refer to §5.9.7 for S3 ingest metadata field details.

5.17 Generic S3 Endpoint

5.17.1 Introduction

Other generic or third-party storage devices and services that support the Amazon S3 protocol may be addressed using the 'Generic S3 Endpoint' feature.

Such endpoints may be used as either migration or ingest destinations.

Additionally, the endpoints may also be used as sources for copy, move and ingest policies. Note that when copying a dataset that did not originate on a filesystem check that the object naming convention will map suitably to the destination filesystem.

5.17.2 Planning

Important: Prior to production deployment, please confirm with Moonwalk that the chosen device or service has been certified for compatibility to ensure that it will be covered by your support agreement.

Prerequisites:

- suitable S3 API credentials
- a license that includes an entitlement for generic S3 endpoints

Dedicated buckets should be used for Moonwalk migration data. However, do not create any S3 buckets at this stage – this will be done later using Moonwalk S3 Config.

Firewall

The S3 port must be allowed by any firewalls between the S3 Plugin on the Moonwalk Gateway Agent and the storage endpoint.

Certificate

In order to utilize an HTTPS endpoint, the endpoint's *Root CA* certificate must be trusted by the relevant Gateway Agent. In most cases the Root CA will already be trusted as a pre-installed public root or enterprise-deployed CA. Where this is not the case, install the *Root CA* (or self-signed certificate) in each Gateway's Local Computer *Trusted Root Certification Authorities* store.

Omit ISO date from path

Normally, when Moonwalk migrates a file to S3, a timestamp is included in each resulting S3 object key (name). *Amazon S3* implements a flat, uniform keyspace – there is no concept of a directory structure within an Amazon storage bucket. However, some S3-compatible devices map the keyspace to an underlying directory structure or other non-uniform or hierarchical namespace. On such systems, the inclusion of the timestamp may result in excessive directory creation which may adversely impact performance and/or resource consumption. For such devices, use the '*Omit ISO date from path*' option to omit the timestamp.

Virtual Host Access

The S3 protocol supports a virtual-host-style bucket access method, for example `https://bucket.s3.example.com` rather than only `https://s3.example.com/bucket`. This facilitates connecting to a node in the correct region for the bucket, rather than requiring a redirect.

Generally the *'Supports Virtual Host Access'* option should be enabled (the default) to ensure optimal performance and correct operation. However, if the generic S3 endpoint in question does not support this feature at all, Virtual Host Access may be disabled.

Note: when using Virtual Host Access in conjunction with HTTPS (recommended) it is important to ensure that the endpoint's TLS certificate has been created correctly. For example, if the endpoint FQDN is `s3.example.com`, the certificate must contain Subject Alternative Names (SANs) for both `s3.example.com` **and** `*.s3.example.com`.

5.17.3 Setup

Installation

To perform a fresh installation:

1. Run the `Moonwalk Agent.exe`, select the Gateway Agent role (see §2.2.2 (p.10)) and select S3 Plugin on the *'Components'* page
2. Follow the prompts to complete the installation

Or, to add the S3 Plugin to an existing Gateway Agent:

1. Run the installer for the Moonwalk S3 Plugin:
`Moonwalk S3 Plugin.exe`
2. Follow the prompts to complete the installation

Installing *'Moonwalk S3 Config'*

- Run the installer for Moonwalk S3 Config:
`Moonwalk S3 Config.exe`

5.17.4 Plugin Configuration

In the *'Moonwalk S3 Config'* tool:

1. Select *'Generic S3 Endpoint'*
2. Enter the Generic S3 target details
3. If required, fill in the *'HTTPS Proxy'* section (not recommended for performance reasons)
4. Enter your S3 account details
5. Select authentication *'Signature Type'*
6. Click **Manage Buckets...**
7. Click **New** to create a new bucket
8. To copy a URI to the clipboard for use in the AdminCenter Destination object:
 - Either click **Get Migration URI** to select a partition for migration use

5.17. GENERIC S3 ENDPOINT

- OR click **Get Ingest URI** for ingest

Configure Encryption-at-Rest

If HTTPS is enabled, all Moonwalk S3 traffic is encrypted *in transit* with TLS.

If encryption-at-rest is to be used to protect **migrated** data on the destination, check *'Enable encryption'*. An encryption key must be generated before Moonwalk can be used to store encrypted data on an S3 migration destination. Moonwalk will encrypt all data migrated using the specified encryption key.

During the encryption key creation process, a copy of the information entered will be printed and it will be strongly recommended that a copy of the `s3generic.cfg` file is stored in a safe location.

1. Click **Generate...** in the *'Moonwalk Encryption Key'* section
2. Read the User Confirmation notice and click **Yes** to continue
3. Keep the suggested Key ID
4. Enter a passphrase from which to generate a new encryption key, and click **OK**
 - *an Encryption Key Details page will be printed*
5. When prompted, enter the *'Validation Code'* from the printed page

Note: Ingested data is not encrypted at-rest.

Apply Configuration to Gateways

1. Click **Save** to save all changes. Changes will be saved to `s3generic.cfg`
2. Ensure the `s3generic.cfg` file has been copied to the correct location on all Gateway machines:
 - `C:\Program Files\Moonwalk\data\Agent\s3generic.cfg`
3. Restart the Moonwalk Agent service on each Gateway machine

5.17.5 Usage

URI Format

For migration – `s3generic://{gateway}/{endpoint}/{bucket}[:{partition}]`

For other uses – `s3generic://{gateway}/{endpoint}/{bucket}[/]{path...}`

Where:

- `gateway` – DNS alias for all Moonwalk S3 Gateways
- `endpoint` – S3 target server FQDN
- `bucket` – name of the S3 destination bucket
- `partition` – an optional partition within the S3 bucket
- `path` – an optional path prefix

If the partition does not already exist, it will be created when files are migrated. If a partition is not specified in the URI, the default partition will be used. It is not necessary to use multiple buckets to subdivide storage. Partitions are useful because *'Create Recovery File from Destination'* Policies are performed on partitions rather than whole buckets.

5.17.6 Ingest Metadata Fields

Please refer to §5.9.7 for S3 ingest metadata field details.

5.18 Microsoft Azure Storage

5.18.1 Introduction

Microsoft Azure is used only as a migration destination with Moonwalk.

5.18.2 Planning

Before proceeding with the installation, the following will be required:

- a Microsoft Azure Account
- a Storage Account within Azure – both General Purpose and Blob Storage (with Hot and Cool access tiers) account types are supported
- a Moonwalk license that includes an entitlement for Microsoft Azure

Firewall

The HTTPS port (TCP port 443) must be allowed by any firewalls between the Moonwalk Azure Plugin on the Moonwalk Gateway Agent and the Internet.

Certificate

The Azure endpoint's *Root CA* certificate must be trusted by the relevant Gateway Agent. In most cases the Root CA will already be trusted as a pre-installed public root or enterprise-deployed CA. Where this is not the case, install the *Root CA* (or self-signed certificate) in each Gateway's Local Computer *Trusted Root Certification Authorities* store.

5.18.3 Setup

Installation

To perform a fresh installation:

1. Run the `Moonwalk Agent.exe`, select the Gateway Agent role (see §2.2.2 (p.10)) and select Azure Plugin on the '*Components*' page
2. Follow the prompts to complete the installation

Or, to add the Azure Plugin to an existing Gateway Agent:

1. Run the installer for the Moonwalk Azure Plugin:
`Moonwalk Azure Plugin.exe`
2. Follow the prompts to complete the installation

Installing '*Moonwalk Azure Config*'

- Run the installer for Moonwalk Azure Config:
`Moonwalk Azure Config.exe`

5.18.4 Plugin Configuration

In the *'Moonwalk Azure Config'* tool:

1. Add a new Azure Storage Account
 - provide Storage Account Name and Access Key
 - provide the Azure Storage endpoint (pre-filled with the default public endpoint)
2. Click **Get URI**:
 - Select *'Create new container. . .'*
 - Enter the name of a new Blob Service container to be used **exclusively** for Moonwalk data
 - An `azure://` URI will be displayed and copied to the clipboard
 - Paste the URI into an AdminCenter Destination, replacing the *gateway* part of the URI as required
3. Optionally, fill in the *'Proxy'* section (not recommended for performance reasons)

Create a Moonwalk Encryption Key

If encryption-at-rest is to be used to protect Moonwalk data on the destination, check *'Enable encryption'*. An encryption key must be generated before Moonwalk can be used to store encrypted data on a Microsoft Azure migration destination. Moonwalk will encrypt all data migrated using the specified encryption key.

During the encryption key creation process, a copy of the information entered will be printed and it is strongly recommended that a copy of the `azure.cfg` file is stored in a safe location.

1. Click **Generate. . .** in the *'Moonwalk Encryption'* section
2. Read the User Confirmation notice and click **Yes** to continue
3. Keep the suggested Key ID
4. Enter a passphrase from which to generate a new encryption key, and click **OK**
 - *an Encryption Key Details page will be printed*
5. When prompted, enter the *'Validation Code'* from the printed page

Advanced Encryption Options

The *'Allow Unencrypted Filenames'* option greatly increases performance when creating Recovery files from an Azure Destination. This is facilitated by recording stub filenames in Azure metadata in unencrypted form.

Even when this option is enabled, stub filename information is still protected by TLS encryption *in transit* but is unencrypted at rest.

File *content* is **always** encrypted both in transit and at rest.

Apply Configuration to Gateways

1. Click **Save** to save all changes. Changes will be saved to `azure.cfg`
2. Ensure the `azure.cfg` file has been copied to the correct location on all Gateway machines:

5.18. MICROSOFT AZURE STORAGE

- C:\Program Files\Moonwalk\data\Agent\azure.cfg
3. Restart the Moonwalk Agent service on each Gateway machine

5.18.5 Usage

URI Format

Note: The following is informational only, Azure Config should always be used to prepare Azure URIs.

```
azure://{gateway}/{storage account}/{container}/
```

Where:

- `gateway` – DNS alias for all Moonwalk Azure Gateways
- `storage account` – Storage Account name for which credentials have been configured
- `container` – container to migrate files to

Example:

```
azure://gateway.example.com/myAccount/finance
```

5.19 Google Cloud Storage

5.19.1 Introduction

Google Cloud Storage is used only as a migration destination with Moonwalk.

5.19.2 Planning

Before proceeding with the installation, the following will be required:

- a Google Account
- a Moonwalk license that includes an entitlement for Google Cloud Storage

Firewall

The HTTPS port (TCP port 443) must be allowed by any firewalls between the Moonwalk Google Plugin on the Moonwalk Gateway Agent and the Internet.

5.19.3 Setup

Installation

To perform a fresh installation:

1. Run the `Moonwalk Agent.exe`, select the Gateway Agent role (see §2.2.2 (p.10)) and select Google Plugin on the 'Components' page
2. Follow the prompts to complete the installation

Or, to add the Google Plugin to an existing Gateway Agent:

1. Run the installer for the Moonwalk Google Plugin:
`Moonwalk Google Plugin.exe`
2. Follow the prompts to complete the installation

Installing 'Moonwalk Google Config'

- Run the installer for Moonwalk Google Config:
`Moonwalk Google Config.exe`

5.19.4 Storage Bucket Preparation

Using the Google Cloud Platform web console, create a new Service Account in the desired project for the **exclusive** use of Moonwalk. Create a P12 format private key for this Service Account. Record the Service Account ID (not the name) and store the downloaded private key file securely for use in later steps.

Create a Storage Bucket **exclusively** for Moonwalk data. Note that the 'Nearline' storage class is not recommended, due to poor performance for policies such as Scrub.

5.19. GOOGLE CLOUD STORAGE

For Moonwalk use, bucket names must:

- be 3-40 characters long
- contain only lowercase letters, numbers and dashes (-)
- not begin or end with a dash
- not contain adjacent dashes

Edit the bucket's permissions to add the new Service Account as a user with at least 'Writer' permission.

Note: Multiple buckets may be used, possibly in different projects or accounts, to subdivide destination storage if desired.

5.19.5 Plugin Configuration

In the *'Moonwalk Google Config'* tool:

1. Configure a new Google Storage Bucket
 - provide the Bucket Name and Service Account credentials
2. Click **Get URI** to copy a URI to the clipboard for use in the AdminCenter Destination object
 - in AdminCenter, fill in the *gateway* and *partition* as required
3. Optionally, fill in the *'Proxy'* section (not recommended for performance reasons)

Create a Moonwalk Encryption Key

If encryption-at-rest is to be used to protect Moonwalk data on the destination, check *'Enable encryption'*. An encryption key must be generated before Moonwalk can be used to store encrypted data on a Google Cloud Storage migration destination. Moonwalk will encrypt all data migrated using the specified encryption key.

During the encryption key creation process, a copy of the information entered will be printed and it is strongly recommended that a copy of the `google.cfg` file is stored in a safe location.

1. Click **Generate...** in the *'Moonwalk Encryption'* section
2. Read the User Confirmation notice and click **Yes** to continue
3. Keep the suggested Key ID
4. Enter a passphrase from which to generate a new encryption key, and click **OK**
 - *an Encryption Key Details page will be printed*
5. When prompted, enter the *'Validation Code'* from the printed page

Apply Configuration to Gateways

1. Click **Save** to save all changes. Changes will be saved to `google.cfg`
2. Ensure the `google.cfg` file has been copied to the correct location on all Gateway machines:
 - `C:\Program Files\Moonwalk\data\Agent\google.cfg`
3. Restart the Moonwalk Agent service on each Gateway machine

5.19.6 Usage

URI Format

Note: The following is informational only, Google Config should always be used to prepare Google URIs.

```
google://{gateway}/{bucket}[:{partition}]/
```

Where:

- `gateway` – DNS alias for all Moonwalk Google Cloud Storage Gateways
- `bucket` – bucket for which credentials have been configured
- `partition` – partition within bucket

Example:

```
google://gateway.example.com/my-bucket:finance/
```

5.20 Alibaba Cloud Object Storage Service (OSS)

5.20.1 Introduction

Alibaba Cloud OSS is used as a migration destination with Moonwalk. Alibaba Cloud is also known as Aliyun.

5.20.2 Planning

Before proceeding with the installation, the following will be required:

- an Alibaba Cloud account
- a license that includes an entitlement for Alibaba Cloud OSS

Dedicated buckets should be used for Moonwalk migration data. However, do not create any buckets at this stage – this will be done later using Moonwalk Alibaba Cloud Config.

Firewall

The HTTPS port (TCP port 443) must be allowed by any firewalls between the Alibaba Cloud Plugin on the Moonwalk Gateway Agent and the Internet.

5.20.3 Setup

Installation

To perform a fresh installation:

1. Run the `Moonwalk Agent.exe`, select the Gateway Agent role (see §2.2.2 (p.10)) and select Alibaba Cloud Plugin on the 'Components' page
2. Follow the prompts to complete the installation

Or, to add the Alibaba Cloud Plugin to an existing Gateway Agent:

1. Run the installer for the Moonwalk Alibaba Cloud Plugin:
`Moonwalk Alibaba Cloud Plugin.exe`
2. Follow the prompts to complete the installation

Installing 'Moonwalk Alibaba Cloud Config'

- Run the installer for Moonwalk Alibaba Cloud Config:
`Moonwalk Alibaba Cloud Config.exe`

5.20.4 Plugin Configuration

In the *'Moonwalk Alibaba Cloud Config'* tool:

1. Enter your Alibaba Cloud account details
2. If required, fill in the *'HTTPS Proxy'* section (not recommended for performance reasons)
3. Click **Manage Buckets...**
4. Click **New** to create a new bucket
5. Click **Get URI** to select a partition and copy a URI to the clipboard for use in the AdminCenter Destination object
 - in AdminCenter, fill in the *gateway* part of the URI as required

Create a Moonwalk Encryption Key

If encryption-at-rest is to be used to protect Moonwalk data on the destination, check *'Enable encryption'*. An encryption key must be generated before Moonwalk can be used to store encrypted data on an OSS migration destination. Moonwalk will encrypt all data migrated using the specified encryption key.

During the encryption key creation process, a copy of the information entered will be printed and it will be strongly recommended that a copy of the `aliyun.cfg` file is stored in a safe location.

1. Click **Generate...** in the *'Moonwalk Encryption Key'* section
2. Read the User Confirmation notice and click **Yes** to continue
3. Keep the suggested Key ID
4. Enter a passphrase from which to generate a new encryption key, and click **OK**
 - *an Encryption Key Details page will be printed*
5. When prompted, enter the *'Validation Code'* from the printed page

Apply Configuration to Gateways

1. Click **Save** to save all changes. Changes will be saved to `aliyun.cfg`
2. Ensure the `aliyun.cfg` file has been copied to the correct location on all Gateway machines:
 - `C:\Program Files\Moonwalk\data\Agent\aliyun.cfg`
3. Restart the Moonwalk Agent service on each Gateway machine

5.20.5 Usage

URI Format

Note: The following is informational only, Alibaba Cloud Config should always be used to prepare Aliyun URIs.

```
aliyun://{gateway}/{bucket}[:{partition}]
```

Where:

- `gateway` – DNS alias for all Moonwalk Alibaba Cloud Gateways

5.20. ALIBABA CLOUD OBJECT STORAGE SERVICE (OSS)

- `bucket` – name of the OSS destination bucket
- `partition` – an optional partition within the bucket

Note: Buckets must be created using Moonwalk Alibaba Cloud Config.

If the partition does not already exist, it will be created when files are migrated. If a partition is not specified in the URI, the default partition will be used. It is not necessary to use multiple buckets to subdivide storage. Partitions are useful because *'Create Recovery File from Destination'* Policies are performed on partitions rather than whole buckets.

5.21 Built-in NFS Client

5.21.1 Introduction

Moonwalk Agents support NFS version 3 using a built-in NFS client. Both TCP and UDP connections are supported, but TCP is preferred by default.

Files cannot be migrated from NFS sources.

5.21.2 Planning

Requirements:

- A license that includes an entitlement for NFS

NFS servers must be configured to share file systems to the servers running the Moonwalk Agent. Typically, NFS servers only allow connections from servers that have been given permission by hostname.

The NFS client accesses NFS servers using a UID of 0 (root) and GID of 1. It may be necessary to configure root squashing behavior accordingly, to allow UID 0 to access the files/folders of interest. See also §E.5 (p.127).

An NFS share point at '/' is not supported.

WORM Devices

Some WORM storage devices present an NFS interface. If using such a device, be sure to set the WORM behavior flag on the Destination in AdminCenter. This will ensure that the agent expects the storage to exhibit this behavior.

NetApp NFS Shares

NetApp filers may not provide an export list to NFS clients via the usual mount protocol. To work around this limitation, NetApp NFS shares created for Moonwalk use must be created to export a top-level directory, e.g. /data.

5.21.3 Setup

NFS file transfer does not require the installation of an additional Moonwalk Gateway Agent.

However, an NFS Browser agent should be installed on the Admin Tools machine to allow browsing of the file systems in the AdminCenter interface and Destination-based policies. Refer to §2.1.3 (p.9) for installation instructions.

5.21.4 Usage

URI Format

`nfs://{servername}/{path}`

Where:

- `servername` – DNS name
- `path` – file system path

Example:

`nfs://nfs.example.com/data`

5.21.5 Behavioral Notes

Symbolic Links

Symbolic links (also known as symlinks or softlinks) will be skipped during traversal of an NFS file system. This ensures that files are not seen – and thus acted upon – multiple times during a single execution of a given policy. If it is intended that a policy should apply to files within a directory referred to by a symbolic link, either ensure that the Source encompasses the real location at the link's destination, or specify the link itself as the Source.

5.22 SMB Protocol Gateway

5.22.1 Introduction

The `smb` scheme allows access to devices using the SMB protocol. Support for the `smb` scheme is provided by Windows Gateway Agents. No plugins are required.

The Migrate operation is not supported for SMB sources. However, support for the Link-Migrate operation with both Dell EMC Isilon and Windows file servers via a Moonwalk LinkConnect Server is detailed in §5.5 and §5.2 respectively.

Legacy URIs

Older versions of Moonwalk provided SMB support via the `cifsnas://` URI scheme. Sources and Destinations using these URIs will continue to work after upgrade and should NOT be updated to use the `smb://` scheme. New Sources and Destinations should use the new scheme.

5.22.2 Planning

Requirements:

- A **Windows** Moonwalk Gateway Agent (see §2.2.2 (p.10)), optionally configured for High-Availability
- A license that includes support for the `smb` scheme

5.22.3 Setup

Ensure the Moonwalk Gateway Agent is run with an appropriate user account that has full access to the NAS device. To set the account to be used by the Moonwalk Agent service:

1. Open Services → Moonwalk Agent
2. Stop the service
3. Right-click and select Properties → Log On tab
4. Check *'This Account'* and enter account name and password
 - If the chosen account is NOT a local Administrator, it **must** be added to the Administrators group before continuing
5. Start the service

5.22.4 Usage

URI Format

`smb://{gateway}/{host}/{share}/[/{path}]`

Where:

5.22. SMB PROTOCOL GATEWAY

- `gateway` – FQDN of Gateway Agent or LinkConnect Server
- `host` – SMB host server
- `share` – SMB share
- `path` – file system path, such as volume and folders

Note: When accessing an SMB share on a device that is configured for Link-Migration, the FQDN of the corresponding LinkConnect Server must be provided. For shares on all other devices, provide the FQDN of any Windows Moonwalk Gateway Agent.

Example:

```
smb://gw.example.com/nas.example.com/pub/projects
```

5.22.5 Behavioral Notes

Junction Points

With the exception of volume mount points, junction points will be skipped during traversal of an SMB share. Symlinks are also skipped. This ensures that files are not seen – and thus acted upon – multiple times during a single execution of a given policy. If it is intended that a policy should apply to files within a directory referred to by a junction point, either ensure that the Source encompasses the real location at the junction point's destination, or specify the junction point itself as the Source.

Chapter 6

Disaster Recovery

6.1 Introduction

The DrTool application allows for the recovery of files where normal backup and restore procedures have failed. Storage backup recommendations and considerations are covered in §3.4 (p.16).

It is recommended to regularly run a *'Create Recovery File From Source'* Policy to generate an up-to-date list of source–destination mappings.

DrTool is installed as part of Moonwalk Admin Tools.

Note: *Starter Edition* licenses do not include DrTool functionality.

6.2 Recovery Files

Recovery files are normally generated by running *'Create Recovery File From Source'* Policies in AdminCenter. To open a file previously generated by AdminCenter:

1. Open Moonwalk DrTool from the Start Menu
2. Go to File → Open From AdminCenter... → Recovery File From Source
3. Select a Recovery file to open

Older versions of Recovery files may be found via the *'Recovery'* page in AdminCenter.

6.3 Filtering Results

In DrTool, click **Filter** to filter results by source file properties. Filter options are described below.

Note: When a Filter is applied, **Save** only saves the filtered results.

Scheme Pattern

In the 'Scheme Pattern' field, use the name of the Scheme only (e.g. `win`, not `win://` or `win://servername`). This field may be left blank to return results for all schemes.

This field matches against the scheme section of a URI:

- `{scheme}://{servername}/[path]`

Server Pattern

In the 'Server Pattern' field, use the full server name or a wildcard expression.

This field matches against the `servername` section of a URI:

- `{scheme}://{servername}/[path]`

Examples:

- `server65.example.com` – will match only the specified server
- `*.finance.example.com` – will match all servers in the 'finance' subdomain

File Pattern

The 'File Pattern' field will match either filenames only (and search within all directories), or filenames qualified with directory paths in the same manner as filename patterns in AdminCenter Rules – see Appendix A.

For the purposes of file pattern matching, the top-level directory is considered to be the top level of the entire URI path. This may be different to the top-level of the original Source URI.

Using the Analyze Button

Analyze assists in creating simple filters.

1. Click **Analyze**
 - Analyze will display a breakdown by scheme, server and file type
2. Select a subset of the results by making a selection in each column
3. Click **Filter** to create a filter based on the selection

6.4 Recovering Files

Selected Files

To recover files interactively:

- Select the results for which files will be recovered
- Click Edit → Recover File...

6.5. RECOVERING FILES TO A NEW LOCATION

All Files

All files may be recovered either as a batch process using the command line (see §6.7) or interactively as follows:

- Click Edit → Recover All Files. . .

Note: Missing folders will be recreated as required to contain the recovered files. However, these folders will not have ACLs applied to them so care should be taken when recreating folder structures in sensitive areas.

6.5 Recovering Files to a New Location

When recovering to a new location, always use an up-to-date Recovery file generated by a 'Create Recovery File From Source' Policy.

To rewrite source file URIs to the new location, use the `-csu` command line option to update the prefix of each URI. Once these URI substitutions have been applied (and checked in the GUI) files may be recovered as previously outlined. The `-csu` option is further detailed in §6.7.

Important: DO NOT create stubs in a new location and then continue to use the old location. To avoid incorrect reference counts, only one set of stubs should exist at any given time.

6.6 Updating Sources to Reflect Destination URI Change

Generally, a Retarget Destination Policy – see §4.11 (p.26) – is the most effective way to permanently move migrated data from one destination to another. If, however, the destination URI changes for some other reason, such as an FQDN being updated externally, DrTool may be used to repair the linkage between the source and the destination.

In DrTool, source files may be updated to reflect a destination URI change through use of the `-cmu` command line option – detailed in §6.7.

To apply the destination URI substitution to *existing* files on the source, select 'Update All Source Files. . .' from the Edit menu. When given the option, elect to update substituted entries only.

Note: This operation must always be performed using an up-to-date Recovery file generated by a 'Create Recovery File From Source' Policy.

6.7 Using DrTool from the Command Line

Important: DO NOT create stubs in a new location and then continue to use the old location. To avoid incorrect reference counts, only one set of stubs should exist at any given time.

Use an **Administrator** command prompt. By default DrTool is located in:

6.7. USING DRTOOL FROM THE COMMAND LINE

C:\Program Files\Moonwalk\AdminTools\drtool\

Interactive Usage:

DrTool [Recovery file] [extra options]

Opens the DrTool in interactive (GUI) mode with the desired options and optionally opens a Recovery file.

Batch Usage

DrTool [<operation> <Recovery file>] [<options>]

Run the DrTool without a GUI to perform a batch operation on all entries in the input file.

Note: The Recovery file provided as input is usually created by saving (possibly filtered) results to the hard disk from the interactive DrTool GUI.

Command Line Options

- operation – is either:
 - -recoverFiles
 - -updateSource
 - if combined with -cmu, only matching entries will be updated
 - -updateSourceAll
 - all entries will be updated, even when -cmu is specified
 - if operation is omitted, the GUI will be opened with any supplied options
- Recovery file – the file to open
- options (related to the operation are):
 - -csu {from} {to} – to change Source URI prefix, this option can be specified multiple times
 - -cmu {from} {to} – to change Migrated URI prefix, this option can be specified multiple times

Examples:

All the following examples are run from the DrTool directory.

- DrTool -recoverFiles result.txt – recover all files from the result.txt file
- DrTool -updateSource result.txt -cmu nfs://oldfqdn/ nfs://newfqdn/ – update existing files to point to a new storage location
- DrTool -recoverFiles result.txt -csu win://old1/ win://new1/ -csu win://old2/ win://new2/ -cmu nfs://oldfqdn/ nfs://newfqdn/ – recover files to different servers and update the secondary storage location simultaneously

6.8 Querying a Destination

While it is strongly recommended to obtain Recovery files from a *'Create Recovery File From Source'* Policy, where this has been overlooked it is possible to obtain Recovery files from the destination. However, some changes in the source file system, such as renames and deletions, may not be reflected in these results.

Querying the Destination from AdminCenter

Run a *'Create Recovery File From Destination'* Policy, see §4.16 (p.29).

Appendix A

Pattern Matching Reference

This appendix details the specifics of the pattern-matching syntax for filename and owner patterns used in Rules (see §1.4.4 (p.4)).

A.1 Wildcard Patterns

The following wildcards are accepted:

- `?` – matches one character (except `'/'`)
- `*` – matches zero or more characters (except `'/'`)
- `**` – matches zero or more characters, including `'/'`
- `/**/` – matches *zero* or more directory components

Literal commas within a pattern must be escaped with a backslash.

Examples of Supported Wildcard Patterns:

- `*` – all filenames
- `*.doc` – filenames ending with `.doc` (including `'doc'`)
- `?*.doc` – filenames ending with `.doc` (excluding `'doc'`)
- `*.do?` – filenames matching `*.doc`, `*.dot`, `*.dop`, etc. but not e.g. `*.docx`
- `???.*` – filenames beginning with any three characters, followed by a period, followed by any number of characters
- `*\,*` – filenames containing a comma

Examples of Using `*` and `**` in Wildcard Patterns:

- `/*.doc` – matches files ending with `*.doc` *directly* within the Source URI location, but *not* within its subdirectories
- `public/*` – matches all files *directly* within *any* directory named `'public'`
- `public/**` – matches all files at *any* depth within *any* directory named `'public'`
- `public/**/*.pdf` – matches all `.pdf` files at *any* depth within *any* directory named `'public'`
- `/home/*.archived/**` – matches the contents of any directory ending with `'archived'` directly within the home directory (`<Source URI>/home`)

A.2. REGULAR EXPRESSIONS

- `/*/public/**` – matches all files at any depth with *any* directory named 'public' where the public directory is *exactly* one level deep within the Source
- `/*/**/public/**` – matches all files at any depth with *any* directory named 'public' where the public directory is *at least* one level deep within the Source

A.1.1 Directory Exclusion Patterns

As shown above, wildcard patterns ending with `'/**'` match all files in a particular tree. When this kind of pattern is used to *exclude* directory trees, Moonwalk will automatically omit traversal of these trees entirely. For large excluded trees, this can save considerable time.

Directory inclusion and exclusion can also be performed using Subdirectory Filtering (see §1.4.2 (p.4)).

A.2 Regular Expressions

More complex pattern matching can be achieved using regular expressions. Patterns in this format **must** be enclosed in a pair of `'` characters. e.g. `/[a-z] .*/`

To assist with correctly matching file path components, the `'` character is **only** matched if used explicitly. Specifically:

- `.` does NOT match the `'` char
- the subpattern `(. | /)` is equivalent to the normal regex `'` (i.e. ALL characters)
- `[^abc]` does NOT match `'` (i.e. it behaves like `[^/abc]`)

Additionally,

- Commas must be escaped with a backslash
- Patterns are matched case-insensitively

It is recommended to avoid regex matching where wildcard matching is sufficient to improve readability.

Examples of Regular Expressions:

- `/.*/` – all filenames
- `/*.doc/` – filenames ending with `.doc`
- `/^[w|$].+ /` – filenames beginning with `~w` or `~$` followed by one or more chars
- `/*. [0-9]{3}/` – filenames with an extension of three digits
- `/public/.+\.html?/` – `.htm` and `.html` files *directly* within *any* 'public' directory
- `/public/(. | /)* /` – equivalent to wildcard pattern `public/**`
- `/public/((. | /)+)*index.html/` – equivalent to `public/**/index.html`

Appendix B

Network Ports

The default ports required for Moonwalk operation are listed below.

B.1 Admin Tools

The following ports must be free before installing Admin Tools:

- 443 (AdminCenter web interface – configurable during installation)
- 8005

The following ports are used for outgoing connections:

- 4604-4609 (inclusive)
- 443 (to contact the Global Licensing Service if using a capacity-based license)

Any firewall should be configured to allow incoming and outgoing communication on the above ports.

B.2 Agent / FPolicy Server / LinkConnect Server

The following ports must be free before installing Moonwalk server components:

- 4604-4609 (inclusive)

Any firewall should be configured to allow incoming and outgoing communication on the above ports.

NFS

For each file server using Moonwalk Agent to connect to an NFS device, open TCP **and** UDP ports for the RPC Portmapper, Mount service and NFS service. Optionally,

B.2. AGENT / FPOLICY SERVER / LINKCONNECT SERVER

a Moonwalk Gateway Agent may be installed on the AdminCenter machine to facilitate browsing; this machine will then also require access to the above ports.

The Portmapper always resides on port 111. The Mount and NFS ports however are registered with the Portmapper and may change when services are restarted. Please refer to firewall documentation regarding SUN RPC and the Portmapper as well as NFS service documentation for further details. The simplest solution is often to force the Mount and NFS services to use fixed port numbers.

Other Ports

Moonwalk plugins may require other ports to be opened in any firewalls to access secondary storage from Gateway Agent machines.

Please consult specific device or service documentation for further information.

Appendix C

AdminCenter Security Configuration

C.1 Updating the AdminCenter TLS Certificate

The webserver TLS certificate may be updated using the following procedure:

1. Go to C:\Program Files\Moonwalk\AdminTools\
2. Run Update Webserver Certificate
3. Provide a PKCS#12 certificate and private key pair

Important: the new certificate **MUST** appropriately match the original AdminCenter FQDN specified at install time.

C.2 Password Reset

Normally, the administration password is changed on the *'Settings'* page as needed.

However, should the system administrator *forget* the username or password entirely, the credentials may be reset as follows:

1. Go to C:\Program Files\Moonwalk\AdminTools\
2. Run Reset Web Password
3. Follow the instructions to provide new credentials

Note: if AdminCenter has been configured to use LDAP for authentication (e.g. to use Active Directory login), then passwords should be changed / reset by the directory administrator – this section applies only to local credentials configured during installation.

C.3 Authentication with Active Directory

Active Directory authentication is configured during installation of Admin Tools.

C.4 Authentication with eDirectory

Installing the CA Certificate

1. Export the LDAP server's *SSL CertificateDNS* object's **Trusted Root Certificate** (without the private key) in Base64 format to a file
2. Install the certificate in the **Local Computer's** Trusted Root Certification Authorities store

Configuring AdminCenter

1. In a text editor, open `C:\Program Files\Moonwalk\AdminTools\Tomcat\conf\server.xml`
 - Follow the instructions in the `server.xml` comments to configure the `JNDIRealm` for eDirectory
2. Restart the '*Moonwalk Webapps*' service

Appendix D

API Access

D.1 Management API

If included in your license, most AdminCenter functions may be invoked via the EMA REST management API. This API can be used to integrate Moonwalk with existing systems in the enterprise for automation, monitoring, statistics analysis and reporting.

EMA API keys are created and revoked from the *'Settings'* page.

D.2 Service Probe

To remotely test whether the Moonwalk Webapps service is responding, perform an HTTP GET request on the following resource:

```
https://<serverFQDN>[:<port>]/eagle/probe
```

For example, to probe with curl:

```
curl -i -k 'https://server.example.com/eagle/probe'
```

The service will respond with 200 OK.

Appendix E

Advanced Agent Configuration

Agents may be configured on a per-server basis via the AdminCenter ‘Servers’ page.

When the configuration options are saved, they are pushed to the target server to be loaded on the next service restart. In the case of a cluster, all nodes will receive the same updated configuration.

E.1 Syslog Configuration

Moonwalk can be configured to send UDP syslog messages in addition to the standard file-based logging functionality. Syslog output is not enabled by default.

Parameter	Description
Severity Threshold	the severity below which messages will be suppressed
Format	RFC5424 and RFC3164 formats are both supported
Facility	the syslog facility (to assist in filtering)
IP/FQDN	the host or broadcast address to which messages will be sent
UDP Port	the syslog port

E.2 Stub Deletion Monitoring

As described in §5.1.7 (p.35), on Windows file systems, Moonwalk can monitor stub deletion events in order to make corresponding secondary storage files eligible for removal using Scrub Policies.

This feature is not enabled by default. It must be enabled on a per-volume basis either by specifying volume GUIDs (preferred) or drive letters. Volume GUIDs may be determined by running the Windows `mountvol` command or Powershell `Get-WmiObject -Class win32_volume`. For Windows clustered volumes, the cluster volume **must** be specified using a volume GUID.

E.3. LOGGING AND DEBUG OPTIONS

Note: This feature should not be configured to monitor events on backup *destination* volumes. In particular, some basic backup tools such as Windows Server Backup copy individual files to VHDX backup volumes in a manner which is not supported and so such volumes **must not** be configured for Stub Deletion Monitoring. Of course, deletions may still be monitored on source data volumes.

E.3 Logging and Debug Options

Log location and rotation options may be adjusted if required. Debug mode may impact performance and should **only** be enabled following advice from Moonwalk Support.

E.4 Parallelization Tuning Parameters

When a Policy is executed on a Source, operations will automatically be executed in parallel. The following parameters can be adjusted:

- Max Slots
 - The maximum number of operations that may be performed in parallel on behalf of a *single* policy for a given Source (default: 8)
- Worker Thread Count
 - The total number of operations that may be performed in parallel across *all* policies on this agent (default: 32)
 - This does not limit the number of policies which may be run in parallel, operations will simply be queued if necessary

Important: take care if adjusting these parameters – over-parallelization may result in lower throughput.

E.5 Advanced NFS Settings

By default, the built-in NFS client accesses NFS servers using a UID of 0 (root) and GID of 1. Wherever possible, NFS exports should be configured to allow such access, rather than reconfiguring the client.

In the case that the defaults above are inappropriate for the target NFS device, NFS client behavior can be adjusted as described below. Settings will apply to **ALL** NFS connections from the given agent.

Parameters

- UID
 - the User ID used to access the NFS share (default: 0)
- GID
 - the Group ID used to access the NFS share (default: 1)
- File Create Mode
 - the permissions set when creating a new regular file (default: 640)
- Directory Create Mode

- the permissions set when creating a new directory (default: 750)

E.6 Demigration Blocking

Applications may be denied the right to demigrate stubs. Such an application – specified either by application binary name or full path – will be unable to access a stub and demigrate the file contents (an error will be returned to the application instead).

Note: Only local applications (applications running directly on the file server) may be blocked.

Appendix F

Troubleshooting

Before contacting Moonwalk Support, please review log files for error messages.

F.1 Log Files

AdminCenter Logs

AdminCenter logs describing each attempted policy operation are accessed through the Recent Tasks panel on the *'Dashboard'*. This is the first place to look when investigating a Policy problem.

The AdminCenter also maintains a *'Global Log'* (accessible from the *'Help'* page) which summarizes Policy start / stop activity.

For other issues, including failure of user-initiated demigrations, it will often be necessary to consult the Agent logs on the machines in question.

Server Statistics

In addition to log files, AdminCenter also provides per-cluster and per-node charts of operation successes and failures on each Server's *'Server Details'* page. This includes information about failed demigrates over time which may be useful in conjunction with a Server's log files to troubleshoot user-initiated demigration issues.

Agent Logs

Location:

- Windows: C:\Program Files\Moonwalk\logs\Agent
- OES Linux: /var/log/moonwalk

There are two types of Agent log file. The `agent.log` contains all Agent messages, including startup, shutdown, and error information, as well as details of each individual

F.2. INTERPRETING ERRORS

file operation (migrate, demigrate, etc.). Use this log to determine which operations have been performed on which files and to check any errors that may have occurred.

The `messages.log` contains a subset of the Agent messages, related to startup, shutdown, critical events and system-wide notifications. This log is often most useful to troubleshoot configuration issues.

Log messages in both logs are prefixed with a timestamp and thread tag. The thread tag (e.g. <A123>) can be used to distinguish messages from concurrent threads of activity.

Log files are regularly rotated to keep the size of individual log files manageable. Old rotations are compressed as gzip (.gz) files, and can be read using many common tools such as 7-zip, WinZip, or zless. To adjust logging parameters, including how much storage to allow for log files before removing old rotations, see §E.3 (p.127).

Log information for operations performed as the result of an AdminCenter Policy will also be available via the web interface.

DrTool Logs

Location: `C:\Program Files\Moonwalk\logs\drtool`

DrTool operations such as recovering files are logged in this location. DrTool will provide the exact name of the log file in the interface.

F.2 Interpreting Errors

Logged errors are typically recorded in an 'error tree' format which enables user-diagnosis of errors / issues in the environment or configuration, as well as providing sufficient detail for further investigation by support engineers if necessary.

Error trees are structured to show WHAT failed, and WHY, at various levels of detail. This section provides a rough guide to extracting the salient features from an error tree.

Each numbered line consists of the following fields:

- WHAT failed – e.g. a migration operation failed
- WHY the failure occurred – the '[ERR.ADD...]' code
- optionally, extra DETAILS about the failure – e.g. the path to a file

As can be seen in the example below, most lines only have a WHAT component, as the reason is further explained by the following line.

A Simple Error

```
ERROR demigrate win://server.test/G/source/data.dat
[0] ERR_DMAGENT_DEMIGRATE_FAILED [] []
  [1] ERR_DMMIGRATESUPPORTWIN_DEMIGRATE_FAILED [] []
    [2] ERR_DMAGENT_DEMIGRATEIMP_FAILED [] []
      [3] ERR_DMAGENT_COPYDATA_FAILED [] []
        [4] ERR_DMSTREAMWIN_WRITE_FAILED [ERR_ADD_DISK_FULL] [112: There is
          not enough space on the disk (or a quota has been reached).]
```

F.2. INTERPRETING ERRORS

To expand the error above into English:

- demigration failed for the file: win://server.test/G/source/data.dat
- because copying the data failed
- because one of the writes failed with a disk full error
 - the full text of the Windows error (112) is provided

So, G: drive on `server.test` is full (or a quota has been reached).

Errors with Multiple Branches

Some errors result in further action being taken which may itself fail. Errors with multiple branches are used to convey this to the administrator. Consider an error with the following structure:

```
[0] ERR...
[1] ERR...
  [2] ERR...
    [3] ERR...
      [4] ERR...
        [5] ERR...
          [6] ERR...
[3] ERR...
  [4] ERR...
    [5] ERR...
```

Whatever ultimately went wrong in line 6 caused the operation in question to fail. However, the function at line 2 chose to take further action following the error – possibly to recover from the original error or simply to clean up after it. This action also failed, the details of which are given by the additional errors in lines 3, 4 and 5 at the end.

Check the Last Line First

For many errors, the most salient details are to be found in the last line of the error tree (or the last line of the first branch of the error tree). Consider the following last line:

```
[11] ERR_DMSOCKETUTIL_GETROUNDROBINCONNECTEDSOCKET_FAILED [ERR_ADD_COULD_NOT_RESOLVE_HOSTNAME] [host was [svr1279.example.com]]
```

It is fairly clear that this error represents a failure to resolve the server hostname `svr1279.example.com`. As with any other software, the administrator's next steps will include checking the spelling of the DNS name, the server's DNS configuration and whether the hostname is indeed present in DNS.

F.3 Getting Help

Join the free Moonwalk user community forum at:

<https://forum.moonwalkinc.com>

Starter Edition users may purchase official support or a full product upgrade. See:

<https://www.moonwalkinc.com/how-to-buy>

F.4 Contacting Support

If an issue cannot be resolved after reviewing the logs, customers with a current maintenance contract should contact Moonwalk Support at:

<https://servicedesk.moonwalkinc.com/>

Include the following information in any support request (where possible):

1. A description of the issue – be sure to include:
 - how long the issue has been present
 - how regularly the issue occurs
 - any changes made to the environment or configuration
 - any specific circumstances which trigger the issue
 - does the issue occur for a particular file and/or server?
2. Moonwalk version
3. Operating System(s)
4. Saved system info (.NFO) from `msinfo32.exe`
5. Plugins in use
6. Source and Destination URIs
7. **Applicable Log Files**
 - see §F.1 for log locations
 - include AdminCenter logs
 - include source agent logs
 - include destination/gateway agent logs
 - remember to include **all** nodes in each agent cluster
 - zip the entire log folders wherever possible
8. **Generate a system configuration file** (`support.zip`) from the AdminCenter 'Help' page
9. Any other error messages – include screenshots if necessary

Important: Failure to include all relevant details will delay resolution of your issue.

Appendix G

Glossary

ACL - Access Control List; file/folder/share level metadata encapsulating permissions granted to users or other entities

CA - Certificate Authority; specifically an X.509 certificate which issues (signs) other certificates such that during certificate validation a chain of trust may be established by verifying the signatures along the certificate chain up to a trusted Root CA certificate, e.g. to facilitate secure connection to a webserver - see also *Root CA*

CLP - Counterfeit Link Protection

Demigrate - to return migrated file content data to its original location, e.g. in response to user access

DFS - Microsoft's Distributed File System; comprised of DFSN and DFSR

DFSN - DFS Namespace; a Windows mechanism allowing for the presentation of multiple SMB shares as a single logical share

DFSR - DFS Replication; an SMB share-based file replication technology, see also Storage Replica as an alternative from Windows Server 2016 onwards

DR - Disaster Recovery

EMA - a REST API providing access to AdminCenter management functions

Enterprise CA - a privately-created Root Certificate Authority, promulgated as a trusted Root CA across an organization

FPolicy - a component of NetApp Data ONTAP which enables extension of native Filer functionality by other applications

FPolicy Server - a server which connects a NetApp Filer via the FPolicy protocols in order to provide extended functionality

FQDN - Fully Qualified Domain Name, e.g. *server1.example.com*

GID - Group ID, e.g. of an UNIX user group

GUID - Globally unique identifier

HA - High-Availability; specifically the provision of redundant instances of a resource in a manner which ensures availability of service, even in the event of the failure of a particular instance

LDM - Link Deletion Monitoring

Link-Migrate - to transparently relocate file content data to secondary storage, replacing the original file with a MigLink

MigLink - a placeholder for a file that has been Link-Migrated; applications accessing the MigLink will be transparently redirected to the corresponding LinkConnect Server to facilitate data access

Migrate - to transparently relocate file content data to secondary storage without removing the file itself; the existing file becomes a *stub*

MWI file - a file on secondary storage which encapsulates the file content data of a corresponding primary storage *stub* file or *MigLink*

NTP - Network Time Protocol, a protocol for clock synchronization between computer systems over a network

Quick-Remigrate - to quickly return a previously demigrated (but unmodified) file back to its migrated state without the need to re-transfer file content data

Root CA - a Certificate Authority at the end (root) of a chain of certificates; a Root CA is *self-signed* and must be trusted *per se* by the validating server (e.g. by inclusion in the computer's Trusted Root Certificate Authorities store)

Recovery File - a text file describing the relationships between stubs/MigLinks and their corresponding MWI files

Scheduler - the AdminCenter component responsible for starting scheduled Tasks

SDM - Stub Deletion Monitoring

Self-Signed Certificate - an X.509 certificate which is *not* attested to by another Certificate Authority, i.e. its Issuer is the same as its Subject; such certificates include Root CAs as well as 'standalone' self-signed server certificates such as may be created automatically during an application's installation process. Self-signed server certificates should generally be replaced with properly issued certificates from a trusted source.

SMB - Server Message Block

Stub - a file whose content data has been transparently migrated to a secondary storage location

Storage Replica - a Windows Server volume replication technology offering synchronous or asynchronous replication modes

Syslog - a protocol used to send system log or event messages, e.g. to a centralized Syslog collector

TLS - Transport Layer Security; a protocol used for establishing secure connections between servers (formerly known as SSL)

UID - User ID, e.g. of an UNIX user

UUID - Universally unique identifier